

# U.S. RADIOISOTOPE THERMOELECTRIC GENERATOR

## SPACE OPERATING EXPERIENCE (JUNE 1961 — DECEMBER 1982)

GARY L. BENNETT, JAMES J. LOMBARDO, AND BERNARD J. ROCK  
OFFICE OF SPECIAL NUCLEAR PROJECTS  
U.S. DEPARTMENT OF ENERGY

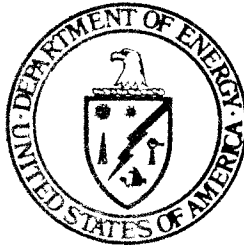

**SAE** The Engineering  
Resource For  
Advancing Mobility

18th  
 **IECEC** '83

**"ENERGY FOR THE MARKETPLACE"**

Sheraton-Twin Towers  
Orlando, Florida  
August 21-26, 1983

The 18th INTERSOCIETY ENERGY CONVERSION ENGINEERING CONFERENCE

U.S. RADIOISOTOPE THERMOELECTRIC GENERATOR SPACE OPERATING EXPERIENCE  
(JUNE 1961 - DECEMBER 1982)

Gary L. Bennett, James J. Lombardo, and Bernard J. Rock

Office of Special Nuclear Projects  
U.S. Department of Energy, Washington, D.C. 20545

ABSTRACT

Since 1961, the United States has used 34 radioisotope thermoelectric generators (RTGs), developed by the Department of Energy and its predecessors, as electrical power supplies in 19 space systems, including navigation and communications satellites launched by the Department of Defense and the Nimbus, Apollo, Pioneer, Viking, and Voyager spacecraft launched by the National Aeronautics and Space Administration. These RTGs have encompassed six design concepts spanning beginning-of-mission power ranges from 2.8 to 159.6 W(e). In general their performance exceeded operational requirements by providing electrical power at or above mission requirements and even exceeded the planned mission lifetime in many cases. The data derived from the diverse uses of these nuclear power sources demonstrate the capability of RTGs to function in a variety of space-mission environments in a manner that is reliable and safe.

INTRODUCTION

The use of nuclear sources of electrical power for space applications has been a key element of some of the more ambitious and spectacular astronomical undertakings of the United States. Nuclear electrical power provided the self-sufficiency that made many of these space missions possible (1).

Since 1961, the United States has successfully used 34 radioisotope thermoelectric generators (RTGs) as electrical power supplies in 19 satellites and spacecraft launched by the National Aeronautics and Space Administration (NASA) and the Department of Defense (DoD) (see Table 1). For this paper these RTGs have been grouped into six basic design concepts: SNAP-3, SNAP-9A, SNAP-19, SNAP-27, TRANSIT-RTG, and MHW-RTG. (SNAP is an acronym for Systems for Nuclear Auxiliary Power, and MHW-RTG stands for the Multihundred-Watt RTG.) The focus of this paper is on the power performance of the various RTG concepts.

The general technology trend for each of these RTG design concepts has been to improve generator performance, efficiency, and specific power. This has led to improvements in the technology of thermoelectric materials, from the lead telluride (PbTe) used in the first five RTG concepts to the silicon germanium (SiGe) used in the MHW-RTG and the RTGs being built for future space missions. Their performance has demonstrated that these nuclear power sources can be safely and reliably engineered to meet a variety of space-mission requirements.

SNAP-3B

The SNAP-3B generators (see Fig. 1) were used as supplementary power sources on the DoD Transit 4A and 4B navigational satellites launched in 1961. These RTGs were used to demonstrate the feasibility of operating nuclear power sources in space. Transit 4A was the first U.S. satellite to use an RTG in space.

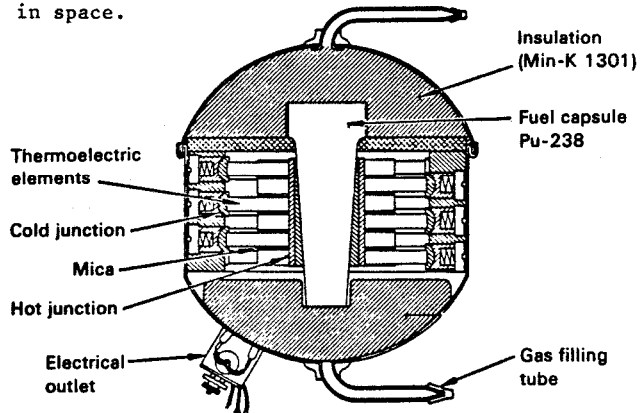

Fig. 1 SNAP-3B RTG

The Transit 4A and 4B RTGs supplied power to the crystal oscillator that was the heart of the electronic system used for doppler-shift tracking. In addition, the RTGs powered the buffer-divider-multiplier, phase modulators, and 54- and 324-MHz power amplifiers. Tracking-station reception of 54- and 324-MHz coherent transmissions at 100- and 50-mW output, respectively, complemented telemetry readout to confirm operation.

POWER SOURCE	NUMBER OF POWER SOURCES	INITIAL AVERAGE POWER PER POWER SOURCE (W)	SPACECRAFT	MISSION TYPE	LAUNCH DATE <sup>a</sup>	INITIAL ORBIT	STATUS
SNAP-3B7	1	2.7	TRANSIT 4A	NAVIGATIONAL	6/29/61 (ETR)	~ 890 X 1000 KM 67.5°, 104 MIN.	SATELLITE SHUT DOWN BUT OPERATIONAL
SNAP-3B8	1	2.7	TRANSIT 4B	NAVIGATIONAL	11/15/61 (ETR)	~ 960 X 1130 KM 32.4°, 106 MIN.	SATELLITE CEASED TRANSMITTING
SNAP-9A	1	> 25.2	TRANSIT 5BN-1	NAVIGATIONAL	9/28/63 (WTR)	~ 1090 X 1150 KM 89.9°, 107 MIN.	SATELLITE CEASED TRANSMITTING
SNAP-9A	1	26.8	TRANSIT 5BN-2	NAVIGATIONAL	12/5/63 (WTR)	~ 1080 X 1110 KM 90.0°, 107 MIN.	NAVIGATIONAL CAPACITY CEASED, BUT SNAP-9A TELEMETRY OPERATIONAL
SNAP-19B	2	28.2	NIMBUS III	METEOROLOGICAL	4/14/69 (WTR)	1070 X 1131 KM 99.9°, 107 MIN.	OPERATIONAL MONITORING CEASED
SNAP-27	1	73.6	APOLLO 12	LUNAR	11/14/69 (KSC)	LUNAR TRAJECTORY	STATION SHUT DOWN
SNAP-27	1	72.5	APOLLO 14	LUNAR	1/31/71 (KSC)	LUNAR TRAJECTORY	STATION SHUT DOWN
SNAP-27	1	74.7	APOLLO 15	LUNAR	7/26/71 (KSC)	LUNAR TRAJECTORY	STATION SHUT DOWN
SNAP-19	4	40.7	PIONEER 10	PLANETARY	3/2/72 (ETR)	SOLAR SYSTEM ES- CAPE TRAJECTORY	STILL OPERATING
SNAP-27	1	70.9	APOLLO 16	LUNAR	4/16/72 (ETR)	LUNAR TRAJECTORY	STATION SHUT DOWN
TRANSIT-RTG	1	35.6	TRIAD	NAVIGATIONAL	9/2/72 (WTR)	716 X 863 KM 90.1°, 101 MIN.	STILL OPERATING
SNAP-27	1	75.4	APOLLO 17	LUNAR	12/7/72 (KSC)	LUNAR TRAJECTORY	STATION SHUT DOWN
SNAP-19	4	39.9	PIONEER 11	PLANETARY	4/5/73 (ETR)	SOLAR SYSTEM ES- CAPE TRAJECTORY	STILL OPERATING
SNAP-19	2	42.3	VIKING 1	MARS LANDER	8/20/75 (ETR)	TRANS-MARS TRAJECTORY	LANDER SHUT DOWN
SNAP-19	2	43.1	VIKING 2	MARS LANDER	9/9/75 (ETR)	TRANS-MARS TRAJECTORY	LANDER SHUT DOWN
MHW-RTG	2	153.7	LES-8	COMMUNICATIONS	3/14/76 (ETR)	35,787 KM 25.0°, 1436 MIN.	STILL OPERATING
MHW-RTG	2	154.2	LES-9	COMMUNICATIONS	3/14/76 (ETR)	35,787 KM 25.0°, 1436 MIN.	STILL OPERATING
MHW-RTG	3	159.2	VOYAGER 2	PLANETARY	8/20/77 (ETR)	SOLAR SYSTEM ES- CAPE TRAJECTORY	STILL OPERATING
MHW-RTG	3	156.7	VOYAGER 1	PLANETARY	9/5/77 (ETR)	SOLAR SYSTEM ES- CAPE TRAJECTORY	STILL OPERATING

<sup>a</sup>KEY TO LAUNCHING STATIONS: ETR, EASTERN TEST RANGE; WTR, WESTERN TEST RANGE; KSC, KENNEDY SPACE CENTER.

Each SNAP-3B generator was designed to provide an initial power output of 2.7 W(e). The heat source was approximately 52.5 W(t) of encapsulated plutonium-238 metal. Earlier RTG feasibility-demonstration devices, which were fueled with the isotope polonium-210, had demonstrated a maximum output of 4 W(e) at 4 V with an overall efficiency of 5.75 percent. The design life for the RTG was 5 years. The power-conversion subsystem consisted of 27 spring-loaded, series-connected pairs of PbTe 2N/2P thermoelectric elements operating at a hot-junction temperature of about 783 K and a cold-junction temperature of about 366 K. (The N elements were doped with lead iodide, and the P elements were doped with sodium.) This subsystem had a power-conversion efficiency on the order of 5 to 6 percent. The Pu-238 fuel capsule and thermoelectric elements were held within a white-coated spun-copper sphere (12.1 cm in diameter and 14 cm high) by a rigid heat-insulating material (Min-K 1301); voids were filled with powdered mica. The mass of SNAP-3B was approximately 2.1 kg. The output of each generator was connected to a part of the satellite load through a DC-to-DC converter that increased the RTG voltage output. The Transit 4A generator (SNAP-3B7) operated with essentially a vacuum inside it to minimize conduction heat losses through the insulation. The Transit 4B generator (SNAP-3B8) was filled with an inert-gas mixture (krypton-hydrogen) to suppress the sublimation of the thermoelectric materials and to minimize the leakage of oxygen into the generator before launch (2-4).

Transit 4A has had the longest operating life of any satellite launched by the United States (4). As shown by the telemetered data in Figure 2, the generator parameters (load voltage, surface temperature) stabilized as predicted with an initial peak power of about 2.8 W(e). (The load-voltage peaks marked with an asterisk in Figure 2 were caused by load reductions during switching.) Although the main transmitter on Transit 4A failed after 17 days of operation (which prevented obtaining detailed data on the operation of SNAP-3B7), the 54- and 324-MHz transmitters continued to send doppler signals that verified the continued operation of the SNAP-3B7 power supply (2, 4, 5). This satellite was still operational in 1976 despite the failure of the telemetry transmitter, the failure of the voltage regulator in the oscillator circuit, and solar-cell degradation, which was reported to be very severe (3).

The initial peak power output of the Transit 4B generator was 3.1 W(e). This generator maintained continuous operation from November 15, 1961, to June 6, 1962, when two excursions from normal to zero power were observed (Fig. 2) as the satellite passed within range of a ground telemetry-receiving station. An analysis of the technical data suggested a capacitor failure some point downstream from the RTG--very likely in the power-conditioning subsystem (3, 4, 5). The solar cells subsequently experienced rapid degradation as a result of a high-altitude nuclear test conducted over the Pacific on July 9, 1962. The satellite ceased transmitting on August 2, 1962. On March 23, 1967,

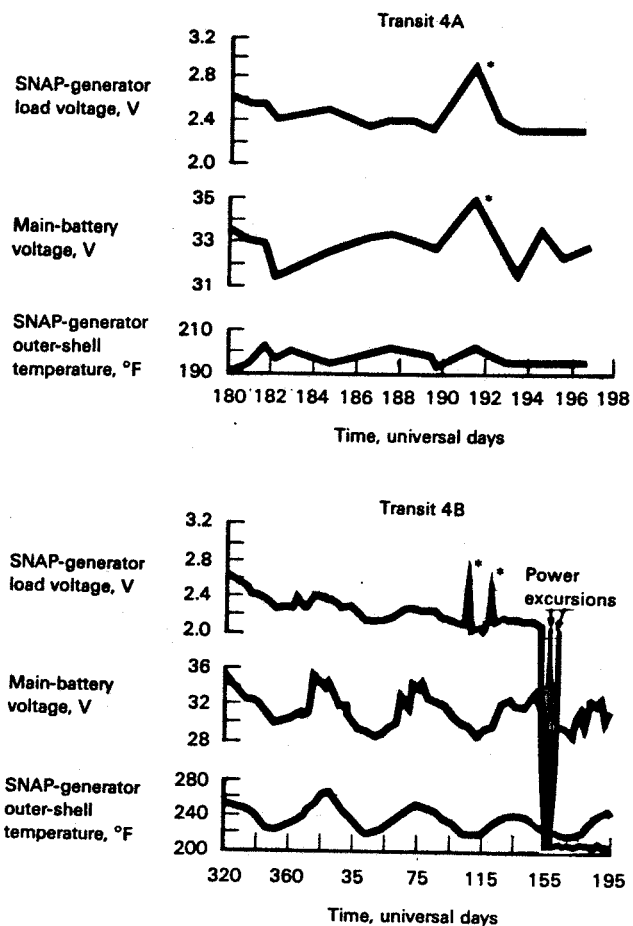

Fig. 2 SNAP-3B Operating Data Telemetered from Transit 4A (top) and Transit 4B (bottom). See text for discussion of voltage changes.

a tracking station in Pretoria, South Africa, picked up signals from Transit 4B (initially at 150 MHz and later at 54 and 324 MHz). The satellite responded to numerous commands during April and May 1967 but finally ceased transmitting. The last reported signal was in April 1971 (4). An analysis of the satellite circuitry by the Johns Hopkins University Applied Physics Laboratory (APL), the builder of the satellite, concluded from the telemetry data that the RTG had to be functioning (6).

From the test experience with the SNAP-3B and later PbTe RTGs, two general modes for the degradation of generator power output were identified:

1. Outgassing of the thermal insulation ( $H_2O$  from the Min-K insulation), which can lead to oxygen attack on PbTe elements and bonds. (The Min-K insulation can also experience structural instability caused by the loss of impurities during high-temperature service.)

2. Increases in generator internal resistance, which occur when the sublimation or loss of thermoelectric material at the hot junction leads to a reduced leg cross section and hence a higher contact resistance.

The second mode was judged to be the more probable, especially in the Transit 4A generator, which had essentially no inert fill gas (3). Research was subsequently undertaken to minimize the magnitude of these degradation modes.

#### SNAP-9A

The SNAP-9A generators (see Fig. 3 and Table 2) were used to provide all of the electrical power for the DOD Transit 5BN-1 and 5BN-2 satellites. (Transit 5BN-1 was the first satellite to rely on an RTG for all primary power.) The RTG approach was selected because the RTGs are inherently radiation resistant, whereas the solar-cell power system of Transit 4B had been adversely affected by the 1962 high-altitude nuclear explosion (3). Each SNAP-9A was designed to provide 25 W(e) at a nominal 6 V for 5 years in space after 1 year of storage on Earth. The SNAP-9A thermal inventory of approximately 525 W(t) was supplied by Pu-238 metal encapsulated in a heat source consisting of six fuel capsules maintained in a segmented graphite heat-accumulator block. The total mass of the generator was about 12.3 kg.

The main body of the sealed generator was a cylindrical magnesium-thorium shell (22.9 cm in diameter and 21.3 cm high) containing six 14-cm-wide heat-dissipating magnesium fins and 36 threaded holes. The surface of the generator had a sodium-silicate-zirconia coating with an emissivity on the order of 0.8. The coating also reduced the escape of the argon cover gas in space. Seventy pairs of series-connected PbTe 2N/2P thermoelectric couples were assembled in 35 modules of two couples each. The modules were sealed with O-rings into 35

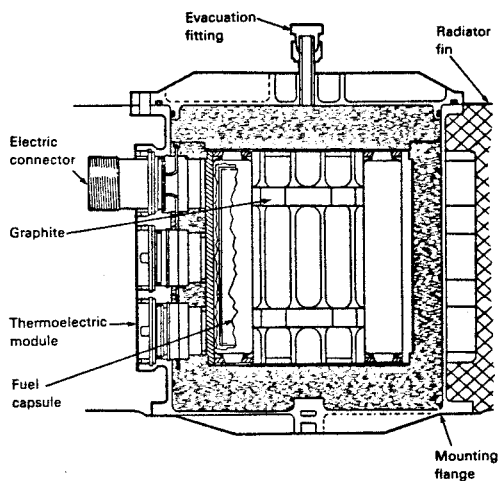

Fig. 3 SNAP-9A RTG

TABLE 2. COMPARISON OF SNAP-9A AND SNAP-19 SYSTEM CHARACTERISTICS AT BEGINNING OF LIFE

CHARACTERISTIC	SNAP-9A*		SNAP-19	
	TRANSIT-5BN	NIMBUS	PIONEER	VIKING*
PERFORMANCE PARAMETERS				
BOM POWER OUTPUT, W(E)	26.8	28.2	40.3	42.7
LOAD VOLTAGE, V DC	6.2	2.68	4.0	4.4
HOT-JUNCTION TEMPERATURE, K	790	800	785	819
FIN ROOT TEMPERATURE, K	431	452	430	450
THERMAL INVENTORY, W(T)	525	628	648	683
DESIGN LIFE, YEARS	5	1	3	2
SPECIFIC POWER, W(E)/KG	2.2	2.1	3.0	2.8
EFFICIENCY, %	5.1	4.5	6.2	6.2
CONFIGURATION				
HEIGHT, CM	26.7	26.7	28.2	40.4
FIN SPAN, CM	50.8	53.8	50.8	58.7
NUMBER OF FINS	6	6	6	6
HOUSING DIAMETER, CM	22.9	16.3	16.8	16.8
MASS, KG	12.3	13.4	13.6	15.2
PBTE THERMOELECTRIC MATERIAL	2N-2P	2N-3P	2N/TAGS-85	2N/TAGS-85
PU-238 FUEL FORM	METAL	PUO <sub>2</sub>	PMC <sup>b</sup>	PMC <sup>b</sup>
MICROSPHERES				

\*THE SNAP-9A DATA ARE NOMINAL VALUES. THE VIKING DATA WERE TAKEN FROM THE INITIAL LANDER CHECKOUTS MADE OVER 2 MONTHS AFTER LAUNCH.

<sup>b</sup>PLUTONIA MOLYBDENUM CERMET.

of the threaded holes, with the 36th hole used as the mounting for the power-output terminals. A button-spring-piston arrangement on each couple ensured contact with the heat-source block. The heat-source block constituted the hot junction for the PbTe elements. The hot-junction temperature was calculated to be about 790 K in space at the beginning of life. (The corresponding calculated cold-junction temperature was 450 K.) Argon gas was used in each generator to inhibit the sublimation of the thermoelectric materials, and Min-K-1301 insulation was used to minimize heat losses. The use of furnace-brazed thermoelectric elements bonded with tin under a hydrogen atmosphere improved the efficiency of the generator and reduced the rate of power degradation caused by increases in internal electrical resistance (3). A DC-to-DC voltage converter increased the 6-V output of the generator to spacecraft levels, regulating five different output voltages to within + 2 percent (3, 7).

One of the objectives of the DoD Transit 5BN program was to demonstrate the satisfactory operation and long-life potential of the SNAP-9A power supply. The Applied Physics Laboratory reported that the objective was fully satisfied. In fact, Transit "5BN-1 demonstrated the extreme simplicity with which thermoelectric generators may be integrated into the design, not only to provide the electrical power but also to aid in thermal control" (4). Some waste heat from the RTG was used to maintain electronic instruments within the satellite at a temperature near 293 K.

Transit 5BN-1, which was launched on September 28, 1963, ceased transmitting on two telemetry bands on December 22, 1963, because of a short-circuit either in one of the satellite wiring harnesses or in the electronics. The excess load caused all outputs from the SNAP-9A converter to be depressed to levels that were insufficient to operate the doppler transmitters. The auxiliary

telemetry system provided some engineering data on the SNAP-9A performance under this heavy load until June 1, 1964, when the final telemetry data were received (4). The available power history is shown in Figure 4.

Transit 5BN-2, launched on December 5, 1963, was the first operational navigational satellite; it was in nearly continuous use until November 1964. Subsequently, its memory exhibited some anomalies, and solar heating rendered the satellite time system inadequate for navigation. All navigational capacity ceased on July 14, 1965; however, the satellite continued to provide SNAP-9A telemetry data until June 1970 (4). The available power history is shown in Figure 4.

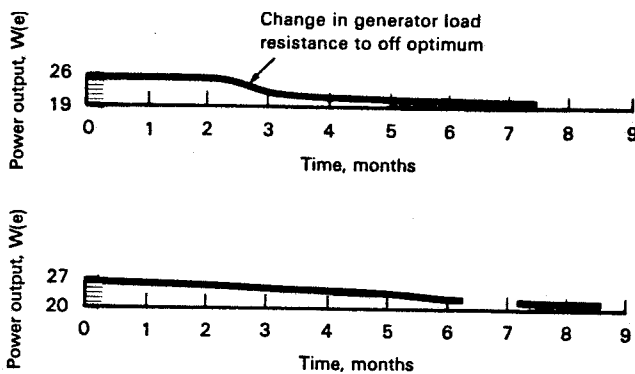

Fig. 4 SNAP-9A Power performance (smoothed data) as telemetered by Transit 5BN-1 (top) and 5BN-2 (bottom). The gap in the Transit 5BN-2 curve reflects the period when APL did not take data.

#### SNAP-19

The SNAP-19 technology-improvement program built on the SNAP-9A development program, with the SNAP-19B power system specifically designed for use on NASA's Nimbus weather satellites. The Nimbus SNAP-19 program was the first demonstration of RTG technology aboard a NASA spacecraft, and, as such, it developed the data and experience to support interplanetary missions using RTGs. Subsequent modifications were made in the SNAP-19B design to power NASA's Pioneer and Viking missions (see Table 2). The Viking SNAP-19 is shown schematically in Figure 5.

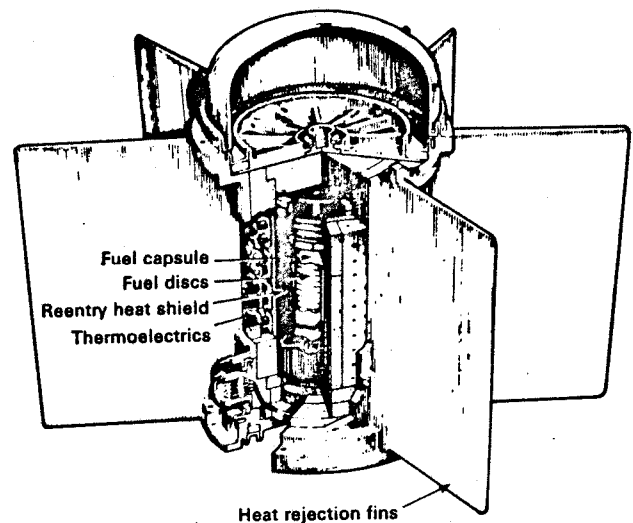

Fig. 5 Viking/SNAP-19 RTG

#### Nimbus/SNAP-19

The SNAP-19 technical interface specification for the Nimbus spacecraft required 50 W(e) deliverable to the regulated-power bus after 1 year in orbit. Such output was considered sufficient to provide significant flexibility for spacecraft experiment programs and perhaps even prolong the lifetime of the mission. (The primary power system of solar arrays and batteries was judged capable of meeting the full spacecraft power requirements (approximately 220 W(e)) for only about 1 month.)

To supply this power, two SNAP-19B RTGs, with higher fuel loadings than those of SNAP-9A, were used on the Nimbus III spacecraft. The RTGs were connected in parallel, with each RTG in series with its own DC-to-DC converter. Thus, a failure of either generator or converter would still permit the isotope power system to operate at half power. The thermoelectric elements were made of cold-pressed and sintered PbTe. Each RTG thermopile consisted of 90 PbTe 3P/2N couples distributed in 6 modules of 3 parallel rows of 5 couples each. The modules were connected in series and enclosed in a magnesium-thorium (HM-31) housing. The couples were metallurgically bonded to iron shoes and maintained under a compressive loading of some 89 N by means of a spring-and-piston assembly. Min-K 1301 was used as the thermal insulation, and argon was used as the cover gas (initial fill pressure of 110 kPa) to reduce the sublimation of the PbTe material at its operating temperature and to minimize the diffusion of atmospheric oxygen into the RTG before launching. The RTGs were sealed with a circumferential Viton-A O-ring and bolted flange-seal arrangement (8). To meet the safety requirements associated with the higher nuclear fuel loading, the Pu-238 fuel was changed from a metal form to oxide microspheres.

Figure 6 shows the performance history of the two SNAP-19 RTGs on Nimbus III, after their launch on April 14, 1969. The two RTGs produced 56.4 W(e) (49.4 W(e) usable) at launch and 47 W(e) 1 year later. This nuclear power comprised about 20 percent of the total power delivered to the regulated-power bus during that time, allowing a number of extremely important atmospheric-sounder experiments to operate in a full-time duty cycle. The RTGs maintained the total delivered power above the spacecraft load line; without them, the total delivered power would have fallen below the load line about 2 weeks into the mission. The monitoring of Nimbus III was terminated on January 22, 1972, at which time the power output of each RTG was under 10 W(e) (9).

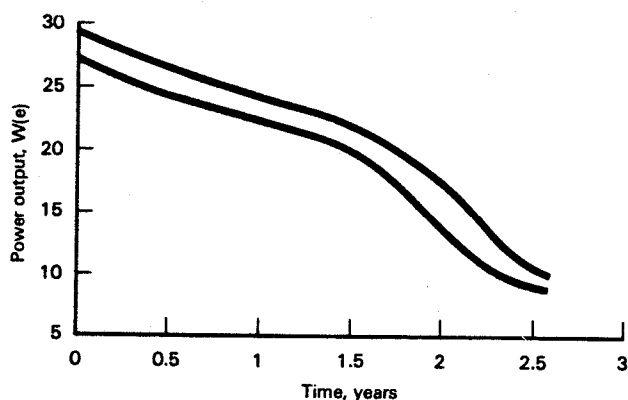

Fig. 6 Nimbus III/SNAP-19 power output (smoothed data).

Overall, the RTG power decreased more rapidly than predicted on the basis of ground test data. This higher power degradation was attributed to the rate of argon leakage from the generator, which was higher than expected, and the replacement of argon by helium from the fuel decay. (Unlike the sealed fuel capsules used in the SNAP-3B and SNAP-9A RTGs, the SNAP-19B fuel capsule was vented into the generator.) The relatively low pressure of the lighter helium would not have protected against PbTe sublimation (10). Oxygen released from the PuO<sub>2</sub> fuel may also have contributed to the observed degradation by increasing the amount of oxygen available for attacking the thermoelectric elements and bonds (8). The design of subsequent RTGs was changed to reduce these sources of degradation.

#### Pioneer/SNAP-19

In order to satisfy the power requirements and environments of NASA's Pioneer Jupiter flyby mission, additional improvements were made to the SNAP-19B converter, heat source, and structural configuration. Specifically, a TAGS-SnTe/2N\* thermocouple was designed to provide higher efficiency and improved longer term power performance. The electrical circuitry was modified to limit the magnetic field from the RTG to very low levels. The fill gas was a 75:25 helium-argon mixture, and

a zirconium getter was added to eliminate any oxygen in the RTG. To reduce gas leakage further, the end covers were bolted and seam-welded to the cylindrical housing. The only leakage path to the outside environment was the O-ring seal around the RTG electrical connector, which served as a pressure-relief device for excess helium generated by the fuel decay (11).

Figure 7 shows the power history of the SNAP-19/Pioneer RTGs, which were launched on March 2, 1972 (Pioneer 10) and April 5, 1973 (Pioneer 11). The mission requirement was that the four RTGs on each Pioneer spacecraft had to produce 120 W(e) total at the Jupiter flyby. The power output of the RTG system at the encounter with Jupiter was 144.0 W(e) for Pioneer 10 and 142.6 W(e) for Pioneer 11. The excellent power performance led to the estimate that the Pioneer RTGs could provide the minimum power requirements (90 W(e)) for a Saturn flyby. The Pioneer 11 RTGs actually provided 119.3 W(e) at Saturn, thereby adding another bonus to the mission. Both Pioneers are still operating 10 to 11 years after their

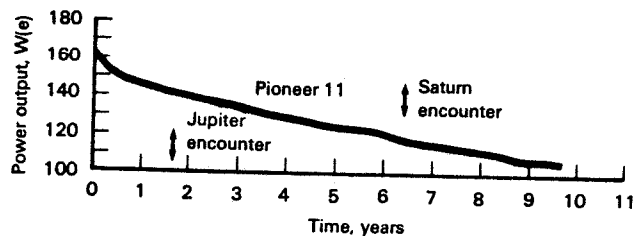
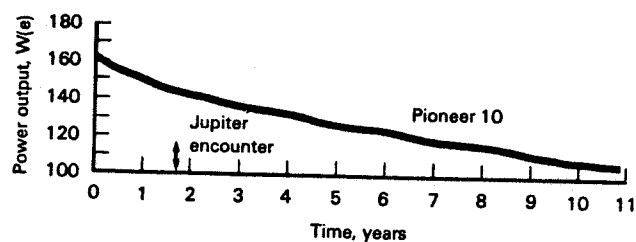

Fig. 7 Power history of Pioneer/SNAP-19 RTGs. (Smoothed and summed data).

\*The acronym TAGS is derived from the names of its major constituents: tellurium, antimony, germanium, and silver. TAGS is a solid solution of silver antimony telluride in germanium telluride. TAGS is an undoped inherent "P" material. The particular material used is sometimes referred to as TAGS-85, and it had a thin SnTe segment at the hot side. The N-leg was 3M-TEGS-2N(M) PbTe.

launches, well beyond their mission design lifetimes, and are providing valuable information about the heliosphere. Pioneer 10 is now farther from the Sun than the planets Neptune and Pluto.

### Viking/SNAP-19

The NASA Viking mission presented a different set of requirements, including high-temperature (400 K) sterilization, storage during the spacecraft's cruise to Mars, and, on the surface of Mars, ability to withstand the thermal cycling caused by the rapid and extreme temperature changes of the Martian day-night cycle. Each Viking Lander used two SNAP-19 RTGs modified to meet these requirements and the performance parameters shown in Table 2. Each RTG was to produce a minimum of 35 W(e) during the 90-day mission on the surface of Mars (the primary mission), which followed the 11- to 12-month cruise from launch. The two series-connected RTGs, which were the primary sources of power on each Viking Lander, supplied the energy for the scientific instruments and for recharging four nickel-cadmium batteries. The RTGs also supplied the Landers with thermal energy, which was used to maintain the Lander electronics at specified operational temperatures (12).

One modification from the Pioneer/SNAP-19 RTG was the addition of a dome reservoir. The initial fill gas for the converter was a 90:10 helium-argon mixture, while the reservoir was filled with a 95:5 argon-helium mixture. The purpose of this configuration was to permit a controlled interchange of gases in these two volumes to minimize heat-source operating temperatures up to launch while maximizing electrical output at the end of the mission (12).

Figure 8 shows the power history of the Viking/SNAP-19 RTGs, which were launched on August 20, 1975 (Viking 1) and September 9, 1975 (Viking 2) (13). All four RTGs met the 90-day requirement.

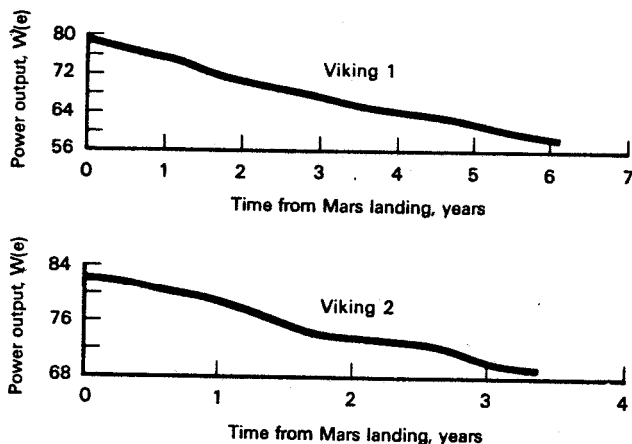

Fig. 8 Power history of the Viking/SNAP-19 RTGs (Summed and smoothed data).

Both Landers successfully operated for several years in an extended mission mode. Viking Lander 2 (VL-2) was inadvertently shut down on February 1, 1980, causing a loss of RTG data. The continuous operation of the VL-2 relay transmitter indicated the RTGs were still operating. The relay capability was lost when the last Viking Orbiter depleted its propellant in August 1980. The RTGs on VL-2 were still operating when the last transmission from Mars was received. In November 1982, all contact with VL-1 was lost after commands had been sent to change the battery charging cycle. The RTGs on VL-1 were capable of providing sufficient power for operation until 1994--18 years beyond the mission requirement.

Both the Pioneer and the Viking SNAP-19 RTGs demonstrated the operability and usefulness of RTGs in interplanetary spacecraft. All of these RTGs performed beyond their mission requirements. The principal contribution to degradation was judged to come from gas effects. It is evident from the outstanding performance data obtained from the Pioneer and Viking SNAP-19s that the changes made to the original SNAP-9A and Nimbus/SNAP-19 designs significantly minimized the degradation effects experienced in these earlier RTGs.

### SNAP-27

The SNAP-27 RTG (14) was developed to power the experiments of NASA's Apollo Lunar Surface Experiments Package (ALSEP). The RTG design requirement was to provide at least 63.5 W(e) at 16 V DC 1 year after lunar emplacement. (In the case of Apollo 17, the requirement was 69 W(e) 2 years after emplacement.) The use of RTGs to power the ALSEPs was a natural choice because of their light weight, reliability, and ability to produce full electrical power during the long lunar night-day cycle. Since the ALSEPs were to be manually positioned by the astronauts, the designers took advantage of this assembly capability. The converter and the sealed-fuel-capsule assembly were kept separately in the Lunar Module and integrated on the Moon. This approach allowed optimization of the electrical, mechanical, and thermal interfaces of the two major hardware subsystems of the RTG.

Figure 9 is a schematic of the SNAP-27 RTG. SNAP-27 used 442 thermoelectric couples made of PbTe 3N/3P elements arranged in two series strings of 221 couples connected in parallel. Each element was preloaded into its hot button (shoe) by individual springs sized and shimmed to establish a bearing pressure of 1.03 MPa. The couples were hermetically sealed in the converter under an argon cover gas at 172 kPa and thermally insulated from each other by powdered Min-K. Heat from the fuel capsule, which was loaded with Pu-238 oxide microspheres and had a nominal rating of 1480 W(t), was transmitted to the hot frame of the RTG by radiation coupling. Both the superalloy (Haynes-25) cladding of the heat source and the Inconel (IN-102) hot frame were coated with a high-emissivity (0.80 to 0.85) iron titanate (Radifrax) coating.



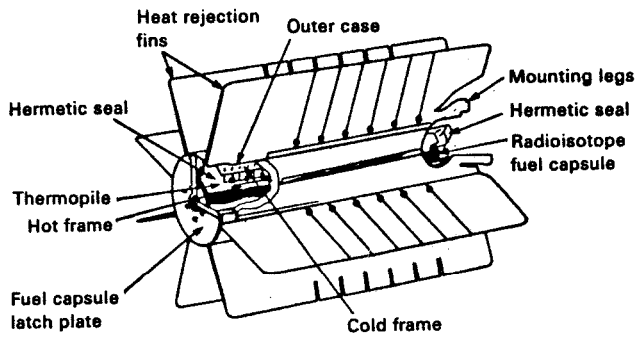

Fig. 9 SNAP-27 RTG

Design analysis and ground tests indicated that the hot-junction temperature was about 866 K, and the cold-side thermoelectric temperature was maintained at about 547 K in the normal operating mode (lunar environment). (The Apollo 12/SNAP-27 initial data indicated a lunar night-day variation of about 855 to 890 K at the hot junction and about 470 to 520 K at the cold junction.) Both the cold frame and the outer case were made of beryllium. Eight cross-rolled beryllium fins with a radial length of 12.7 cm were integrally attached to the outer case by brazing.

The converter was 46 cm high and 40.0 cm in diameter (including fins); together with a 3-m-long cable plus connector, it had a mass of 12.7 kg. The mass of the fuel-capsule assembly without the graphite lunar module fuel cask was about 7 kg. Each flight RTG was acceptance tested for not less than 500 hours, of which at least 200 hours was spent in a thermal-vacuum environment.

On November 19, 1969, Apollo 12 astronauts Charles Conrad Jr. and Alan L. Bean assembled the first nuclear-power ALSEP. Four additional SNAP-27-powered ALSSEPs were subsequently emplaced on the lunar surface. The performance of the SNAP-27 RTGs is shown in Figure 10 (15). In each case all of the RTGs exceeded their mission requirements in both power and lifetime. This performance was achieved by the RTGs despite the variable duty cycle and the temperature extremes of the lunar day-night cycle. Through this performance beyond mission requirements, the SNAP-27 RTGs enabled the ALSEP stations to gather long-term scientific data on the internal structure and composition of the Moon, the composition of the lunar atmosphere, the state of the lunar interior, and the genesis of lunar surface features. All five RTG-powered ALSSEPs were operating when NASA shut down the stations on September 30, 1977.

TRANSIT RTG

The TRANSIT RTG was developed specifically as the primary power for the DoD TRIAD navigational satellite, which was launched on September 2, 1972. Auxiliary power was provided by four solar-cell panels and one 6-Ah nickel-cadmium battery. The

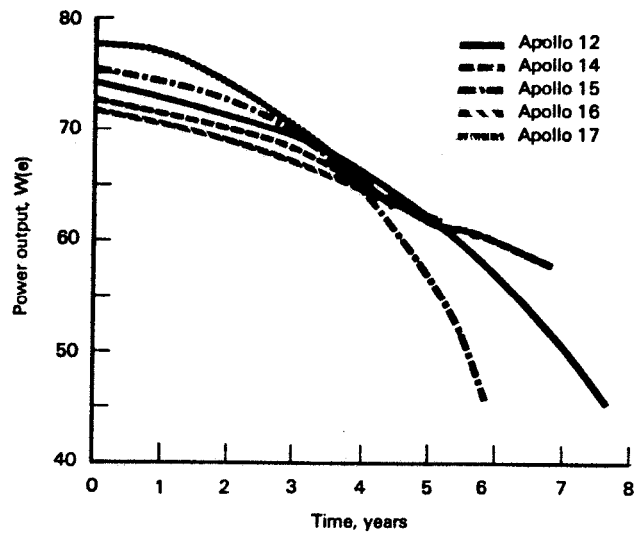

Fig. 10 Power history of the SNAP-27 RTGs (smoothed data).

objective of the TRANSIT RTG program was to produce an RTG capable of providing a minimum end-of-mission (EOM) power of 30 W(e) after 5 years at a minimum of 3 V. To do this, the 12-sided converter (see Fig. 11) used light-weight PbTe thermoelectric panels (Isotec) that operated at a low hot-side temperature (673 K) in a vacuum, thereby eliminating the need for hermetic sealing and a cover gas to inhibit the sublimation of thermoelectric material.

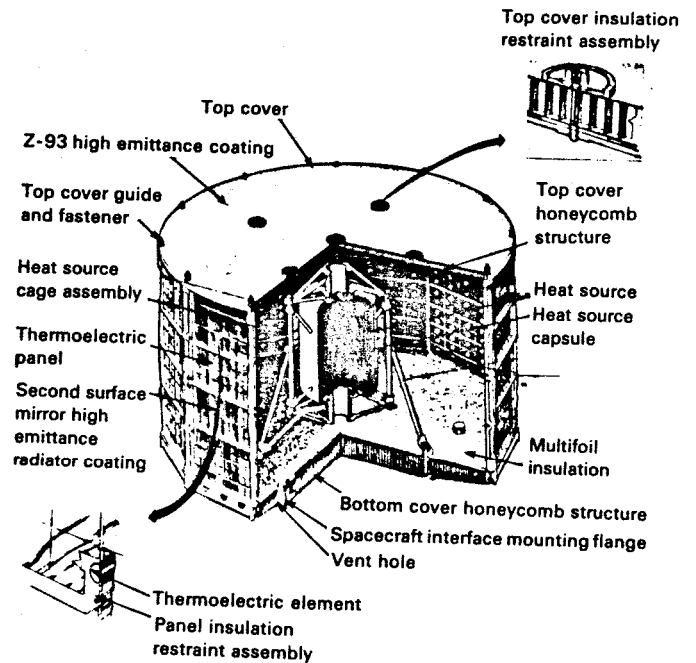

Fig. 11 Transit RTG

The TRANSIT RTG was designed to be modular. The modular panel construction allowed increases or decreases in power as required by the mission, and the converter design was independent of the 855-W(t) heat-source configuration, which improved design and operational flexibility. Each of the 12 Isotec panels (14.5 by 36.3 cm) contained 36 PbTe 2N/3P couples arranged in a series-parallel matrix with 4 couples in a row in parallel and 9 rows in series. The panels were structurally supported by 12 webbed magnesium-thorium corner posts with teflon insulators. The distance across flats was 61 cm. Each panel was designed to produce about 3.2 W(e) at about 0.5 V. Molybdenum-opacified paper washers were used to form a sleeve around each element to reduce thermal losses and to prevent potential sublimation of the thermoelectric material. The primary insulation consisted of 32 alternate layers of aluminum foil and aluminum-opacified quartz paper. A multifoil insulation blanket was also used in the top-cover and bottom-cover assemblies which were otherwise principally made of aluminum honeycomb and magnesium-thorium face sheets. The masses of the converter and the heat source were 5.98 and 4.2 kg, respectively. Including the titanium heat-source cage and support structure, the TRANSIT RTG had a mass of about 13.6 kg.

The short-term objectives of the TRIAD satellite were demonstrated, including a checkout of RTG performance; however, a telemetry-converter failure on October 2, 1972, caused a loss of further RTG telemetry data. The TRIAD satellite continues to operate normally and is providing useful magnetometer data, which testifies that the TRANSIT RTG is a dependable power source. Table 3 summarizes the available TRANSIT data (16).

TABLE 3. IN-ORBIT PERFORMANCE OF THE TRANSIT RTG

PERFORMANCE PARAMETER	PREDICTED	MEASURED <sup>a</sup>	
		FIRST 20 DAYS	25-30 DAYS
POWER OUTPUT, W(E)	36.2 ± 0.5	35.6 ± 0.5	35.4 ± 0.2
AVERAGE HOT-CAP TEMPERATURE, K	673 ± 4	674 ± 2	673.6 ± 0.7
AVERAGE COLD-CAP TEMPERATURE, K	412 ± 4	410 ± 4	410.6 ± 1.1
LOAD VOLTAGE, V	5.6 ± 0.2	5.70 ± 0.1	(b)
LOAD CURRENT, A	6.5 ± 0.2	6.25 ± 0.2	(b)

<sup>a</sup>AVERAGE OF DAY AND NIGHT PASSES OVER THE APL TRACKING STATION, INCLUDING BEFORE AND AFTER SPACECRAFT BOOM DEPLOYMENT AND STABILIZATION.

<sup>b</sup>DATA NOT REPORTED. A REVIEW OF SOME RAW DATA SUMMARIES SHOWS THE LOAD VOLTAGE WAS ABOUT 5.58 V WITH A CURRENT OF ABOUT 6.21 A.

#### MULTIHUNDRED-WATT (MHW) RTG

The MHW-RTG (see Fig. 12) was designed to provide a major increase in the power output of a space RTG (17). The DoD Lincoln Experimental Satellites 8 and 9 (LES 8/9) required 125 W(e) per RTG, with an output voltage of 30 (+0.5) V at the end of mission--an operational life of at least 5 years after launch. The NASA Voyager mission re-

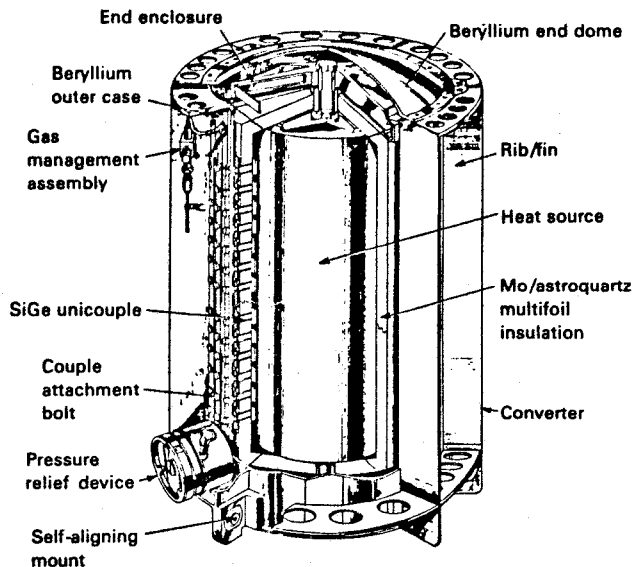

Fig. 12 MHW-RTG

quired 128 W(e) minimum per RTG, with an end-of-mission output of 30 (+0.5) V, or an operational life of at least 4 years after launch. To achieve these requirements, the MHW-RTG was equipped with a new heat source of 24 pressed plutonium oxide fuel spheres, each producing about 100 W(t). Electrical conversion was achieved through 312 silicon-germanium (SiGe) thermoelectric couples.

The use of high-temperature SiGe alloys as thermoelectric power-conversion materials was a direct outgrowth of spacecraft requirements for higher RTG power levels and lower RTG masses (i.e., improved efficiencies). In general, a higher hot-side operating temperature means a higher efficiency, although the optimum temperature is dictated by the mission life (i.e., minimizing sublimation). The cold-side temperature is optimized to obtain the desired power-to-mass ratio. To a first approximation, PbTe can be used from room temperature to about 900 K before materials properties and the figure of merit become concerns. The SiGe alloy can be used from room temperature to about 1300 K and offers the potential of higher power with an improved efficiency. Furthermore, SiGe RTGs generally do not require an inert atmosphere for space operation because the temperatures (1300 K or less) are normally below those at which sublimation presents a problem. (The use of multifoil insulation does necessitate sealing the RTG under an inert atmosphere on Earth to protect the molybdenum foil against oxidation.)

As shown in Figure 12, the converter consists of a beryllium outer case, which is the main support structure for the thermoelectric elements and for the heat source; end-closure structures that physically hold the heat source; thermoelectric elements; a multifoil (molybdenum-Astroquartz) insulation packet and a molybdenum internal frame;

and a gas-management system. The gas-management system maintained an argon or xenon gas environment to allow partial power operation on the launch pad; full-power operation in space was effected by venting the gas through a pressure-relief device. (Several modifications were made for the Voyager mission: the forward ring of the converter case was reinforced for the increased loading predicted for the mission; an iridium canister and the associated pressure-maintenance device were deleted to reduce weight; and the mounting of the pressure-relief device was changed.) The overall diameter of the RTG was 39.73 cm, and its length was 58.31 cm. The average RTG flight masses were 39.69 kg for LES 8/9 and 37.69 kg for Voyager 1/2.

The 312 thermoelectric couples (see Fig. 13) were arranged in 24 circumferential rows, each row containing 13 couples individually bolted to the outer case. The couples, which are called "unicouple assemblies," supported the insulation packet. The unicouple also contained the silicon-molybdenum (85 wt% Si) hot shoe to which the SiGe thermocouple legs were bonded. Two compositions of the SiGe alloy were used in the legs: 78 at.% Si for most of the length and a short segment of 63.5 at.% Si at the cold end of the couple. The purpose of using this segment with a lower silicon content was to match the thermal expansion of bonded parts. The N-type material was doped with phosphorus and the P-type with boron. The SiGe couple was bonded to a cold stack assembly of tungsten, copper, and Al<sub>2</sub>O<sub>3</sub> parts that separated the electrical and thermal elements. Except for the lower-silicon segments and the hot shoes, a coating of Si<sub>3</sub>N<sub>4</sub> was applied to the thermocouple legs to retard silicon sublimation.

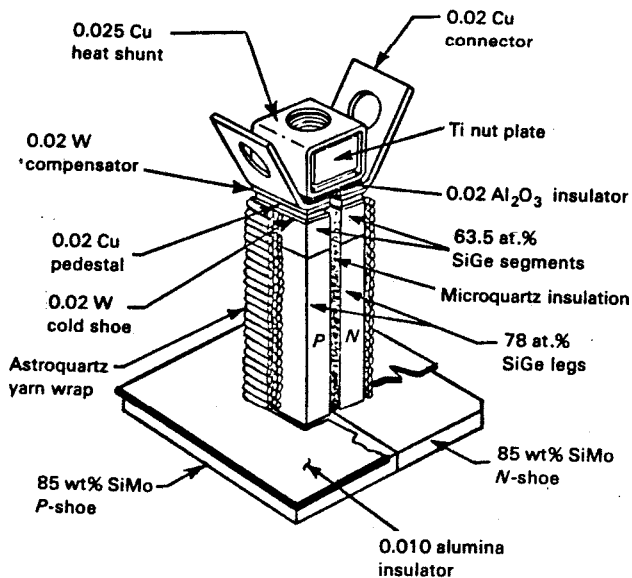

Fig. 13 Silicon Germanium Unicouple (used on MHW-RTG and GPHS-RTG).

A two-string, series-parallel electrical wiring circuit was used. The thermocouples were electrically insulated from the multifoil insulation by several layers of Astroquartz yarn tightly wound around the two SiGe legs of each couple and by an Al<sub>2</sub>O<sub>3</sub> wafer behind the hot shoe. The design hot-junction temperature was 1273 K (hot-shoe temperature 1308 K) with a cold-junction temperature of 573 K. The design voltage was 30 V.

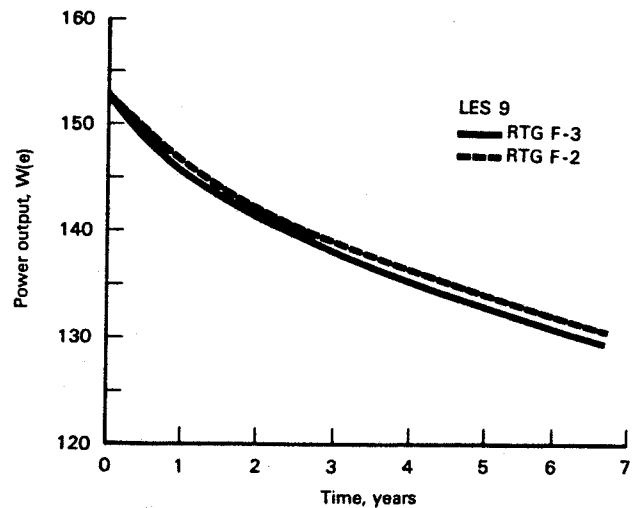
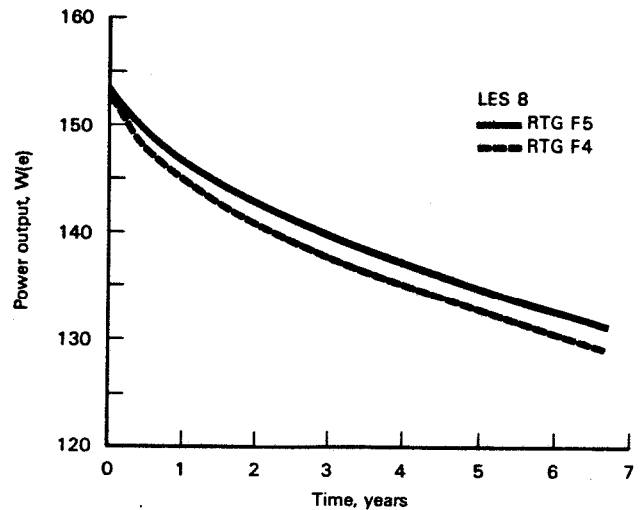

Fig. 14 Power history for LES 8 MHW-RTGs (top) and LES 9 MHW-RTGs (bottom). (Smoothed data).

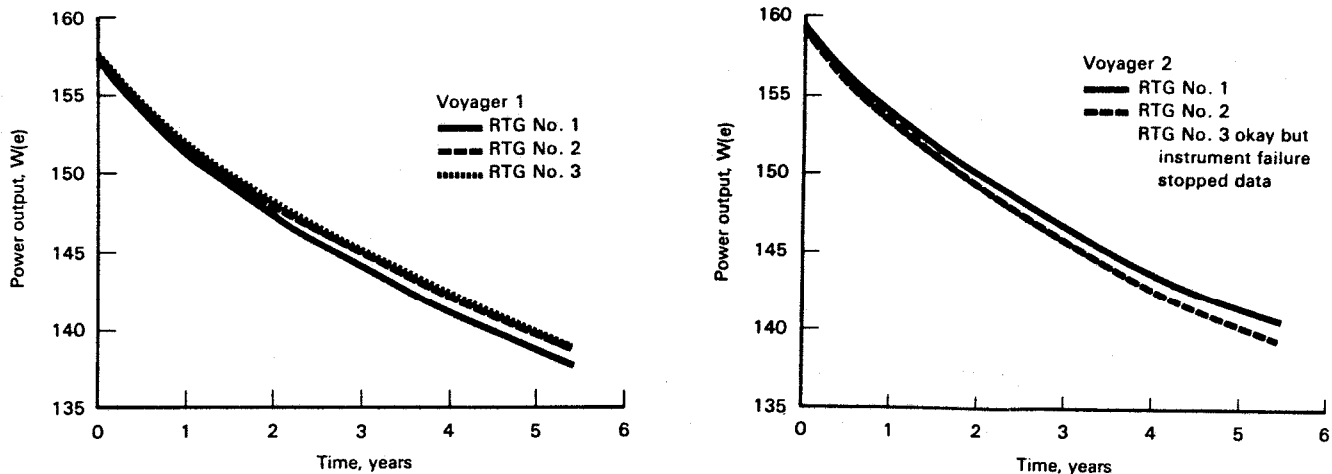

Fig. 15 Power history for Voyager 1 MHW-RTGs (left) and Voyager 2 MHW-RTGs (right). (Smoothed data).

Figures 14 and 15 show the MHW-RTG power history from launch to December 31, 1982, for LES 8/9 and Voyager 1/2, respectively (18). The peak initial power was 159.6 W(e) for RTG No. 3 on Voyager 2. (An instrument failure on Voyager 2 has precluded obtaining power data from the third RTG, but the RTG continues to operate satisfactorily.) The MHW-RTGs have allowed the LES 8/9 satellites to operate beyond the 5-year operational life. Moreover, they have allowed NASA to complete flights to Jupiter and Saturn and will enable Voyager 2 to conduct an extended mission to Uranus in 1986.

During and after the MHW-RTG development program, a number of analytical and experimental studies were undertaken to determine the long-term performance of the MHW-RTGs. Four principal de-

gradation modes were identified: (1) dopant-precipitation effects, (2) increases in the conductance of the thermal insulation, (3) degradation of the electrical insulation, and (4) CO effects (17). The flight data have shown a steady decrease in overall degradation as the effect of dopant precipitation has diminished. No evidence of appreciable contributions from the other degradation modes has been found in the flight data.

The successful performance of the MHW-RTGs has led to the use of the SiGe technology for the high-power (285 W(e)) General Purpose Heat Source RTG, (GPHS-RTG), which is to be launched in 1986 on the NASA Galileo Mission to Jupiter and the International Solar Polar Mission about the Sun (1).

Table 4 illustrates the trends in RTG technology from SNAP-3B to GPHS-RTG, showing the overall steady progress to date.

TABLE 4. TRENDS IN RTG TECHNOLOGY

PARAMETER	SNAP-3B	SNAP-9A	SNAP-27	TRANSIT-RTG	SNAP-19	MHW-RTG	GPHS-RTG
MISSION	TRANSIT 4	TRANSIT 5BN	APOLLO	TRIAD	PIONEER	VOYAGER	GALILEO
BOM POWER PER RTG, W(E)	2.7	26.8	73.4	35.6	40.3	158.0	292.0
THERMOELECTRIC MATERIAL	PBTE 2N/2P	PBTE 2N/2P	PBTE 3N/3P	PBTE 2N/3P	PBTE 2N/TAGS-85	SIGE	SIGE
PU-238 FUEL FORM	METAL	METAL	OXIDE MICRO-SPHERES	PMC <sup>a</sup>	PMC <sup>a</sup>	PRESSED OXIDE	PRESSED OXIDE
CONVERSION EFFICIENCY, %	5.1	5.1	5.0	4.2	6.2	6.6	6.6
SPECIFIC POWER W(E)/KG	1.29	2.2	2.3 <sup>b</sup>	2.6	3.0	4.2	5.2

<sup>a</sup> PLUTONIA MOLYBDENUM CERMET.

<sup>b</sup> THE SNAP-27 SPECIFIC POWER IS SHOWN WITH THE FUEL-CASK MASS INCLUDED.

## CONCLUSION

RTGs have proved to be reliable, long-life sources of electrical power that have enabled the conduct of a number of important U.S. space missions. In general, the RTGs, from SNAP-3B to the MHW-RTG, exceeded their mission requirements by providing power at or above that required and beyond the planned mission lifetime.

## ACKNOWLEDGMENTS

The authors acknowledge their indebtedness to all of the authors of IECEC papers on RTGs for much useful information. Special thanks for supplying information go to Paul J. Dick of Teledyne Energy Systems (TES), John Dassoulas and Walt Allen of the Johns Hopkins University Applied Physics Laboratory (JHU/APL), G. Stapfer of the Jet Propulsion Laboratory (JPL), C. E. Kelly of the General Electric Company Advanced Energy Programs Department (GE/AEPD), Frank D. Postula of GA Technologies, Inc. and E. A. Skrabek of Fairchild Industries. The authors acknowledge with thanks the contributions made to the U.S. RTG program by members of the staffs of GE/AEPD, TES, TRW, Gulf General Atomic, JHU/APL, NUS Corporation, Fairchild Industries, Battelle Columbus Laboratories, Thermo Electron Corporation, 3M Company, JPL, RCA, Mound Plant, Savannah River Plant and Laboratory, the Los Alamos National Laboratory, the Oak Ridge National Laboratory, Sandia National Laboratories, the Ames Laboratory, and the associated Department of Energy Operations Offices.

## REFERENCES

1. G. L. Bennett, J. J. Lombardo, and B. J. Rock, "Nuclear Electric Power for Space Systems: Technology Background and Flight Systems Program", Paper 819181, Proceedings of the 16th IECEC, August 9-14, 1981, Atlanta, Georgia.
2. P. J. Dick and R. E. Davis, "Radioisotope Power System Operation in the Transit Satellite", Paper No. CP 62-1173, AIEE Summer General Meeting, June 17-22, 1962, Denver, Colorado.
3. Hittman Associates, Inc., Radioisotope Powered Space Systems, NYO-3165-11, August 23, 1963.
4. Johns Hopkins University Applied Physics Laboratory, Artificial Earth Satellites Designed and Fabricated by the Johns Hopkins University Applied Physics Laboratory, JHU/APL Report SDO-1600 (revised), August 1980.
5. D. G. Harvey, P. J. Dick, and C. R. Fink, "Isotope-Generator Reliability and Safety", Nucleonics, Vol. 21, No. 4, April 1963.
6. Private communication from Walt Allen, Johns Hopkins University Applied Physics Laboratory, March 11, 1983.
7. P. J. Dick, SNAP-9A Quarterly Progress Report No. 2, Radioisotope-Fueled Thermoelectric Power Conversion System Development, December 1, 1961 through February 28, 1962, MND-P-2700-2, undated.
8. A. W. Fihelly and C. F. Baxter, "Orbital Performance of the SNAP-19 Radioisotopic Thermoelectric Generator Experiment", Paper 719152, Proceedings of the 6th IECEC, August 3-5, 1971, Boston, Massachusetts.
9. H. Jaffe and P. O'Riordan, "Isotope Power Systems for Unmanned Spacecraft Applications", Paper 729088, Proceedings of the 7th IECEC, September 25-29, 1972, San Diego, California.
10. P. Rouklove and V. Truscello, "Long Term Tests of a SNAP-19 Thermoelectric Generator," Paper 729038, Proceedings of the 7th IECEC, September 25-29, 1972, San Diego, California.
11. C. J. Goebel, "SNAP-19 Pioneer 10 and 11 RTG Deep Space Performance", Paper 759130, Record of the 10th IECEC, August 18-22, 1975, Newark, Delaware.
12. W. M. Brittain, "SNAP-19 Viking RTG Mission Performance", Paper 769255, Proceedings of the 11th IECEC, September 12-17, 1976, State Line, Nevada.
13. W. M. Brittain and E. A. Skrabek, "SNAP 19 RTG Performance Update for the Pioneer and Viking Missions", Proceedings of the 18th IECEC, August 21-26, 1983, Orlando, Florida.
14. A. A. Pitrolo, B. J. Rock, W. C. Remini, and J. A. Leonard, "SNAP-27 Program Review", Paper 699023, Proceedings of the 4th IECEC, September 22-26, 1969, Washington, D.C.
15. J. R. Bates, W. W. Lauderdale, and H. Kernaghan, ALSEP Termination Report, NASA Reference Publication 1036, 1979.
16. G. B. Bradshaw and F. D. Postula, "Beginning of Mission Flight Data on the TRANSIT RTG", Paper 739091, Proceedings of the 8th IECEC, August 13-16, 1973, Philadelphia, Pennsylvania.
17. C. E. Kelly, "The MHW Converter (RTG)", Paper 759132, Record of the 10th IECEC, August 18-22, 1975, Newark, Delaware.
18. V. B. Shields, International Solar Polar Mission, Progress Report No. 2 on SiGe Technology Evaluation Task for GPHS RTG, 1628-36, JPL D-575, February 1983.