

## Mound Laboratory (Mound Facility)<sup>1</sup>

**ADDRESS:** Monsanto Research Corporation/  
Mound  
P.O. Box 32  
Miamisburg, OH 45342  
513/865-4020

**LOCATION:** Miamisburg, Ohio, south of Dayton; 180-acre site<sup>2</sup>

**MISSION:** The production of non-nuclear components of nuclear weapons, development of processes for the nuclear weapons program, and surveillance testing of explosive and nuclear components

**MANAGEMENT:** GOCO facility operated for DOE by Monsanto Research Corporation, a wholly owned subsidiary of Monsanto Chemical Company. Administered by Albuquerque Operations Office

**ESTABLISHMENT:** Organization established 1948 in Dayton, Ohio; permanent facility construction begun 1947

**BUDGET:** \$216.0 million, (FY 1986)

**PERSONNEL:** 2364 (March 1985)

**FACILITIES:** (see text)

### History

Mound Laboratory originated as a technical organization in 1943 in Dayton, Ohio, when Monsanto Chemical Company's Central Research Department took responsibility for determining the chemical and metallurgical properties of polonium for the Manhattan Engineer District. Construction of permanent facilities then called the Dayton Engineer Works, in Miamisburg, Ohio, began in 1947 and buildings were first occupied in 1948. The plant was assigned new production and development functions in 1955, and oversight was shifted from the Oak Ridge Operations Office.<sup>3</sup>

### Nuclear Weapons Activities

Mound produces detonators, cable assemblies, explosively actuated timers and firing sets, command disable explosive components, and surveillance testing equipment.



Figure 29 Aerial View of Mound Facility

Operations at Mound include disassembly, analysis and development of nuclear components containing tritium, and recovery of wastes.<sup>4</sup> Tritium is recovered from weapon components at Mound and reprocessed at Savannah River.<sup>5</sup> Mound's work with tritium began in 1954.

Mound is an integrated production and laboratory facility. It fabricates ceramic components for actuators, igniters, and detonators; formulates pyrotechnic materials; and manufactures pyrotechnic devices. New facilities for the development and production of ceramics were constructed in the late 1970s.

Laboratories are uniquely equipped for work on tritium technology, radioactive heat sources, diagnostic testing of explosive components, and the separation and purification of stable isotopes.

<sup>1</sup> Initially called Dayton Engineer Works.

<sup>2</sup> The site overlooking the Miami River is adjacent to the largest natural Indian mound in the state, from which the name Mound Laboratory is derived.

<sup>3</sup> An Introduction to Mound, Monsanto Research Corporation, Miamisburg, Ohio, April 1983.

<sup>4</sup> Draft Background Information Document, Proposed Standards for Radionuclides, EPA 520/1-83-001, U.S. EPA, March 1983, p. 2.10-1.

<sup>5</sup> HAC, FY 1983 EWDA, Part 4, p. 156.

## Mound Laboratory

### Nonweapon Activities

About 25 percent of the facilities at Mound are non-defense.

Mound provides a large number of enriched stable (non-radioactive) isotopes and is the single DOE distributor in the United States of stable isotopes for structural studies, precision calorimetry, and its applications to accurate measurements of the properties of radioactive materials. Other uses are in agricultural biology, cryogenics, geology, and medicine.

Other major nonweapon activities are the production of thermoelectric heat sources (plutonium-238) for the U.S. space program<sup>6</sup> and surveillance satellites; energy research including solar energy, fossil fuels, and thermite (chemical) heat sources; environmental research including tritium recovery technology; isotope enrichment by chemical exchange; nuclear waste management; and work on nuclear materials safeguards for the NRC. Current activities include the recovery of tritium from aqueous waste and the design, construction, and testing of a tritium storage and delivery system for the Tokamak fusion reactor at Princeton.

### Facilities

The original explosive component test facility was built in 1957 to support a single weapon system. Three additional detonator test cells, each capable of withstanding a 10 lb TNT detonation, are under construction (starting FY 1984).<sup>7</sup> Equipment at Mound includes an infrared laser and focusing system, laser welder, and positioner; also, volume measuring equipment and an environmental test chamber. Mound has a building for handling tritium. Analytical capabilities include atomic absorption spectrophotometry, infrared spectrometry, neutron activation analysis, and electron microscopy.

Mound has developed techniques for the laser isotope separation of tritium from aqueous waste and a pilot electrolysis system for recovering tritium from water. DOE has implemented a program to provide a partial backup of the SRP's tritium container filling capability by providing functionally similar facilities at the Mound Plant.

Mound has equipment for forming and molding plastics and precision machining capabilities for fabrication of metal and nonmetal parts. It is implementing a program for computer aided design and manufacturing (CAD/CAM). It has a graphics system for automated machine tool programming, and computer controlled machine tools are being installed for specialized operations.

### Testing and Surveillance

Studies of new detonator designs as well as tests of current production items require the use of flash x-ray technology, interferometry, computer data reduction, and other advanced diagnostic techniques. Explosive components are prepared, detonated, and evaluated in the Mound component test facility. This facility, which occupies 23,000 square feet in four buildings, is built around eight test cells where as many as seventy-five separate testing programs are available.

Surveillance of aged warhead components, many of which are returned to Mound for testing after several years in the nuclear weapon stockpile, gives component designers important information on the long-term reliability of electrical parts and explosive compounds. Surveillance, electrical testing, disassembly, and test fire data obtained for non-nuclear components of nuclear weapons at many locations throughout Mound are recorded and stored in a central computer data base to audit the components as they move through the facility.

Nondestructive testing (NDT) of ultrasonic, eddy current, dye penetrant, and leak testing techniques are used in the quality control program at Mound. The californium multiplier (CFX) neutron radiography facility permits onsite NDT inspection of sealed components. The CFX facility, installed in 1977, produces quality radiographs previously possible only with a nuclear reactor as the neutron source.

BUDGET <sup>8</sup> (\$ million):	FY	Total	DOE Defense
		DOE	Programs
	1981	87.9	77.3
	1982	118.2	89.9
	1983	134.7	124.8
	1984	161.6	151.3
	1985	198.4	186.2
	1986	216.0	202.0

**ASSETS** Capital investment and equipment, \$116.8 million (FY 1980). Ninety-five buildings total 880,000 square feet of floor space (1983).

6. Thermoelectric generation in support of the NASA Galileo program and International Solar Polar Mission (ISPM); HAC, FY 1984 EWDA, Part 4, p. 675.

7. HAC, FY 1985 EWDA, Part 4, p. 224.

8. An Introduction to Mound, op. cit.; Estimated costs from DOE, FY 1986 Budget Request Estimates for Laboratories, Office of the Controller, 22 February 1985, pp. 55-56.

<b>PERSONNEL:<sup>9</sup></b>	<b><u>End FY</u></b>	<b><u>Total Personnel</u></b>
	1971	1808
	1972	1813
	1973	1830
	1974	1731
	1975 (Sep)	1575
	1976	1567
	1977	1675
	1978	1690
	1979	1714
	1980	1811
	1981	1910
	1982	2060
	1983	2161
	1984	2302
	1985 (Mar)	2364

<sup>9</sup> DOE, COCO Employment, Computer printout for Office of Industrial Relations, R-1529509-012, 29 August 1985.

## Nevada Test Site (NTS)<sup>1</sup>

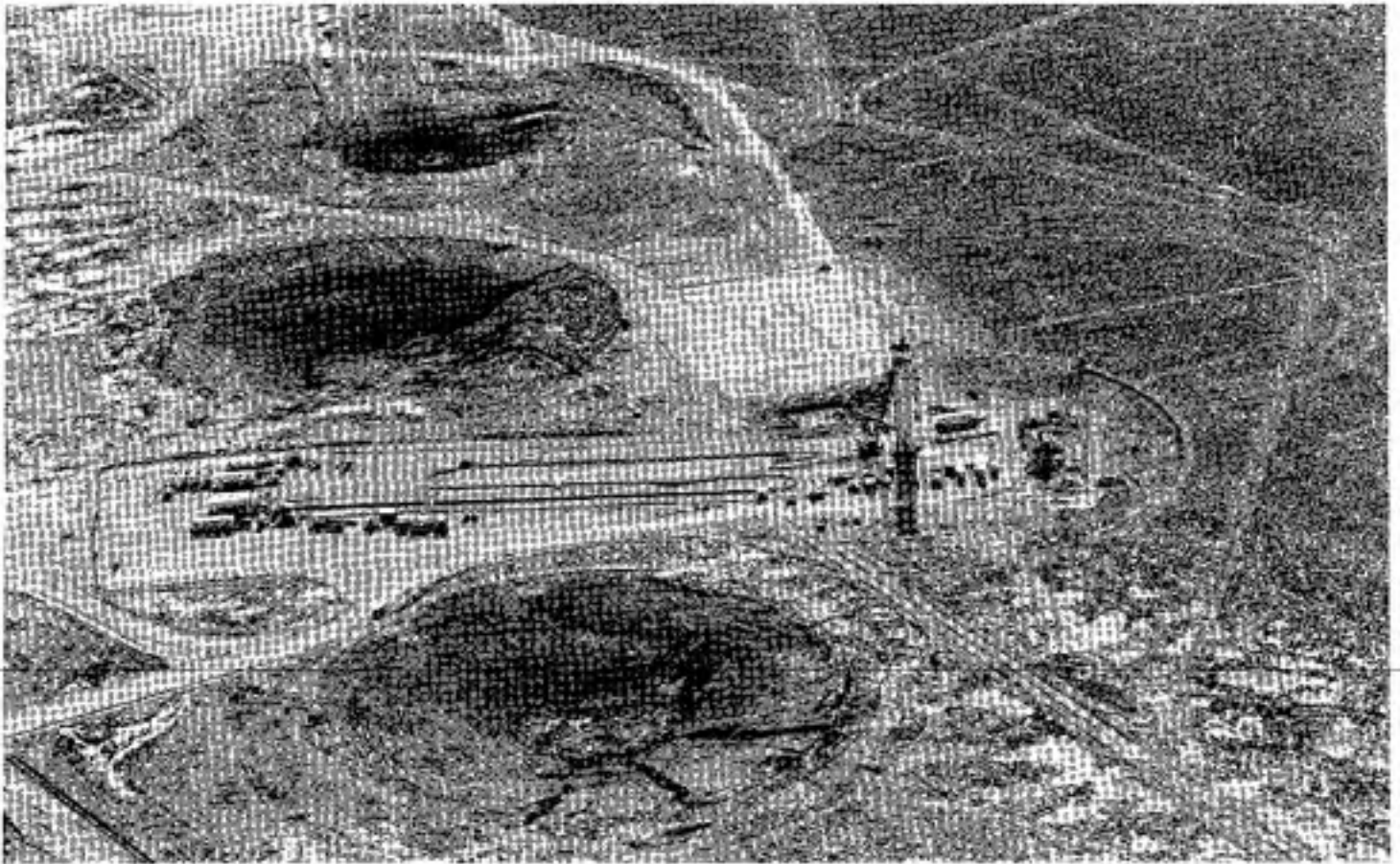

**Figure 30** Final test preparations include running miles of cable downhole which will transmit test information to diagnostic trailers

(left). The instrumentation rack is in the lower (right). Subsidence craters from earlier underground tests dot the landscape.

**ADDRESS:** U.S. Department of Energy  
Nevada Operations Office  
2753 South Highland Drive  
P.O. Box 14100  
Las Vegas, NV 89114  
702/295-1000 (295-3521, Public Affairs)

**LOCATION:** Adjacent to Nellis Air Force Base and training area, about 65 miles northwest of Las Vegas, Nevada; 1350-square-mile site; ATLAS facilities at North Las Vegas used for management support, pretest staging, and diagnostic activities

**MISSION:** Field testing of nuclear weapons to determine their effectiveness and capability in support of the

nuclear weapons laboratories. The NTS is also used by the United Kingdom as a test site.

**MANAGEMENT:** Administered by Nevada Operations Office (see text for list of contractors)

**ESTABLISHMENT:** Chosen as continental proving ground in December 1950; first nuclear test 27 January 1951

**BUDGET:** \$484 million, (FY 1986)

**PERSONNEL:** 8414 (March 1985)

**FACILITIES:** Nuclear weapons testing and diagnostic facilities

<sup>1</sup> Formerly part of Las Vegas Bombing and Gunnery Range, then Site Mercury, then Nevada Proving Ground.



## History

The Nevada Test Site was chosen as a continental proving ground in December 1950. The first nuclear test at NTS was conducted on 27 January 1951. The Nevada Operations Office (NV) was created and assumed responsibility for operations and programs at NTS on 6 March 1962 when nuclear testing became a year-round effort.<sup>2</sup>

## Nuclear Weapons Activities

There are two principal types of nuclear weapons tests conducted at NTS: weapon-related tests and weapon effects tests (see Volume II, Chapter Two).

Testing is conducted during four stages of weapon development: primary experimental research, theoretical investigations and calculations, component development experimentation, and full-scale proof-testing. Most tests involve developmental devices conceived and furnished by Los Alamos National Laboratory (LANL) and Lawrence Livermore National Laboratory (LLNL), with non-nuclear contributions by Sandia National Laboratories (SNL).

The other major test site activities include supporting Defense Advanced Research Projects Agency (DARPA) detection tests and Defense Nuclear Agency (DNA) Field Command military effects tests.<sup>3</sup>

## Nonweapon Activities

The Nevada Applied Ecology Group, a management umbrella for some fifteen organizations, oversees research on areas of NTS that were contaminated by atmospheric weapons tests. Research is conducted on the inventory and distribution of various radionuclides; movement of the radioactive materials in soils and by resuspension; uptake into plants, animals, and microorganisms; and modeling estimates of radionuclide uptake and resultant radiation doses to humans living in contaminated environments.

A bioenvironmental experimental farm, operated some sixteen years for DOE through an agreement with the U.S. Environmental Protection Agency (EPA), was used to conduct radionuclide uptake studies on various farm animals and crops. The farm was closed on 30 December 1981.

The tuffaceous rock at the Yucca Mountain Site, on and adjacent to the southwest portion of the NTS, is currently being examined by DOE as a potential site for disposal of spent nuclear fuel high-level radioactive waste. DOE proposes to recommend to the President Yucca Mountain Site as one of the three candidate sites for site characterization in accordance with the Nuclear Waste Policy Act.

During the 1960s and through 1973 the Jackass Flats area of NTS was used as a test site for the Atomic Energy Commission's ROVER nuclear rocket engine develop-

ment program. In February 1962 this area was designated the Nuclear Rocket Development Station (NRDS). The hot cells and remote handling equipment of the Engine Maintenance, Assembly, and Disassembly Building (EMAD) at the NRDS site are currently used to prepare unprocessed spent nuclear fuel from commercial power reactors for surface and subsurface dry storage experiments. Tests include placement of canned spent fuel in granitic rock 1400 feet underground in facilities located in the northeastern part of NTS that were used for nuclear weapons effects tests in the 1960s.

## Facilities

Each underground test involves a complex series of activities including the manufacture of the nuclear device, the drilling of a test shaft to conduct the test, the construction of the metal canister that holds the device, and the diagnostic equipment associated with a particular test, and assembly of the diagnostic equipment.

A wide array of equipment (over 45,000 items in inventory) is located at NTS, including digital equipment, television cameras, and radiochemical detectors.

The nuclear devices are provided by one of the weapons laboratories. Two device assembly and storage facilities, one for LANL and one for LLNL, have historically been used at NTS. A project is underway to consolidate these activities at a new Combined Device Assembly facility that will be completed in 1989. Funds are requested for construction of four "Gravel Gertie" assembly structures, two radiography facilities, three high bay areas, three assembly areas/bunkers and one storage area, several special nuclear material/high-explosive storage bunkers (various sizes), two laboratory support buildings for storage, and an administration building. The 34-foot diameter Gravel Gerties are designed to contain a 500 lb HE explosion.<sup>4</sup>

Due to the size of the nuclear weapons canisters containing diagnostic equipment, test shafts are large compared, for example, to oil and gas wells, which are typically less than a foot in diameter. In the early days at NTS, small diameter holes were drilled and then widened by reaming. At NTS bore holes up to 12 feet in diameter and thousands of feet deep can be drilled in one pass. Examples of big hole drilling today are a 90-inch-diameter hole about 6100 feet deep on Amchitka and a hole 120 inches in diameter more than 5000 feet deep in Nevada.

The ATLAS facility at North Las Vegas, Nevada, serves as an assembly area for diagnostic canisters. Management, administrative, and technical support and computer warehousing is also provided. It is being expanded (FY 1985) to handle additional and larger devices and canisters.

2 DOE, DOE's Nevada Operations Office: What It Does and Why, undated, p. 1.

3 DNA is charged by the Joint Chiefs of Staff with the responsibility to conduct nuclear weapons effects tests.

4 HAC, FY 1986 ESWDA, Part 4, pp. 217-23; IIAC, FY 1986 ESWDA, Part 7, p. 204.

## Nevada Test Site

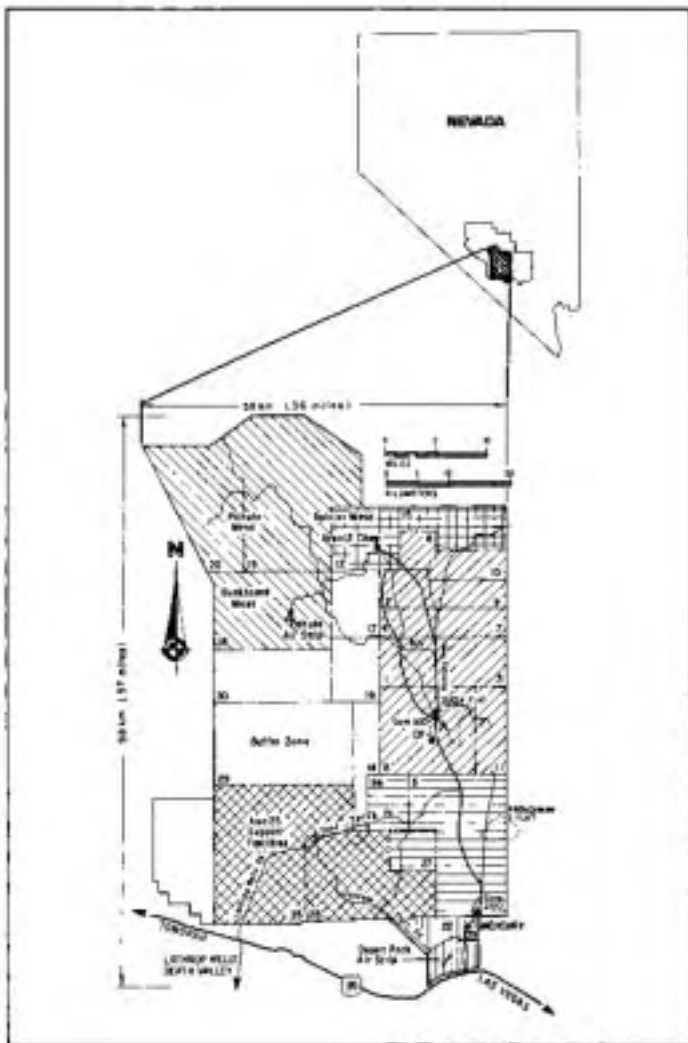

**Figure 31** Map Showing Location of Nevada Test Site and Nevada Test Site Regions

### Management

The Nevada Test Site is administered by the Nevada Operations Office. The major operating contractors for DOE are Reynolds Electrical and Engineering Company (REEC), a subsidiary of EG&G, Inc. (formerly Edgerton, Germeshausen, and Grier, Inc.); Holmes and Narver, Inc.; and Fenix and Sission. REEC is the principal support contractor. REEC operates the test site and conducts drilling for underground tests and minor construction. REEC's parent company, EG&G, is also a technical contractor at NTS, operates the ATLAS facility in North Las Vegas, and prepares diagnostic electronics and other equipment used in nuclear tests. Holmes and Narver provides architect-engineering services. Fenix and Sission engineers and logs test holes. Westinghouse Advanced Energy Sys-



**Figure 32** Nevada Test Site Topography

tems Division operates the E-MAD facility used for commercial nuclear waste activities.

BUDGET <sup>5</sup> (\$ million):	DOE Defense Programs	
	FY	Total DOE
	1981	200.2
	1982	301.9
	1983	379.1
	1984	399.1
	1985	451.3
	1986	484.0

### ASSETS

The book value for all facilities at NTS (1983/1984) is about \$400 million, with the replacement costs in excess of \$2 billion.<sup>6</sup>

### PERSONNEL:<sup>7</sup>

End FY	EG&G <sup>8</sup>	Fenix & Sission	Holmes & Narver	Reynolds Electric Energy	Total
1975	1192	71	192	1843	3297
1976	1289	71	211	1834	3405
1977	1431	82	236	1670	3420
1978	1519	102	258	1740	3619
1979	1560	100	247	1760	3667
1980	1698	105	274	1818	3895
1981	1840	109	351	2209	4509
1982	2055	116	387	2422	4980
1983	2151	124	445	4791	7511
1984	2300	114	501	5155	8069
1985 (Mar)	2355	119	531	5409	8414

<sup>6</sup> Includes all EG&G, Inc. personnel under the Nevada Operations Office including those at Albuquerque, New Mexico; Las Vegas, Nevada; San Ramon, California; Santa Barbara, California; Los Alamos, New Mexico; and Woburn, Massachusetts.

<sup>5</sup> Figures for 1984-86 Estimated costs, DOE, FY 1986 Budget Request, Estimates for Labor Plans, Office of the Controller, 22 February 1985, pp. 50-52.

<sup>6</sup> NNSC, FY 1984 DOE, p. 309.

<sup>7</sup> DOE, GOCO Employment, Computer printout for Office of Industrial Relations, R-5529309-015, 29 August 1985.

## Oak Ridge Reservation

<b>ADDRESS:</b>	Oak Ridge Operations Office P.O. Box E Oak Ridge, TN 37831 615/576-5454 (Information) 615/576-1000 (Assistance)
<b>LOCATION:</b>	East central Tennessee, eastern Roane County and western Anderson County, adjacent to Oak Ridge, Tennessee, which is approximately 20 miles (by air) west of Knoxville; 37,000-acre site
<b>MISSION:</b>	Carries out a variety of nuclear weapons and nonweapons activities for DOE, including uranium enrichment
<b>MANAGEMENT:</b>	GOCO site managed for DOE by Martin Marietta Energy Systems, Inc.
<b>ESTABLISHMENT:</b>	Selected 19 September 1942 (Site X) as site for enrichment of uranium
<b>BUDGET:</b>	(see specific Oak Ridge facilities)
<b>PERSONNEL:</b>	16,554 (March 1985)
<b>FACILITIES:</b>	<ul style="list-style-type: none"> <li>• Oak Ridge Gaseous Diffusion Plant</li> <li>• Oak Ridge National Laboratory</li> <li>• Y-12 Plant</li> </ul>

### History

The Conant-Bush report, approved by President Roosevelt on 17 June 1942, recommended that a full-scale atomic bomb development project be initiated by the United States and urged that a search for an appropriate production site or sites for enriched uranium and plutonium be undertaken immediately. Shortly thereafter the Manhattan Engineer District was organized within the U.S. Army Corp of Engineers under the command of then Colonel (later Major General) Leslie R. Groves. The decision to locate a development site in East Tennessee, code named Site X,<sup>1</sup> was made by Colonel Groves on 19 September 1942.<sup>2</sup>

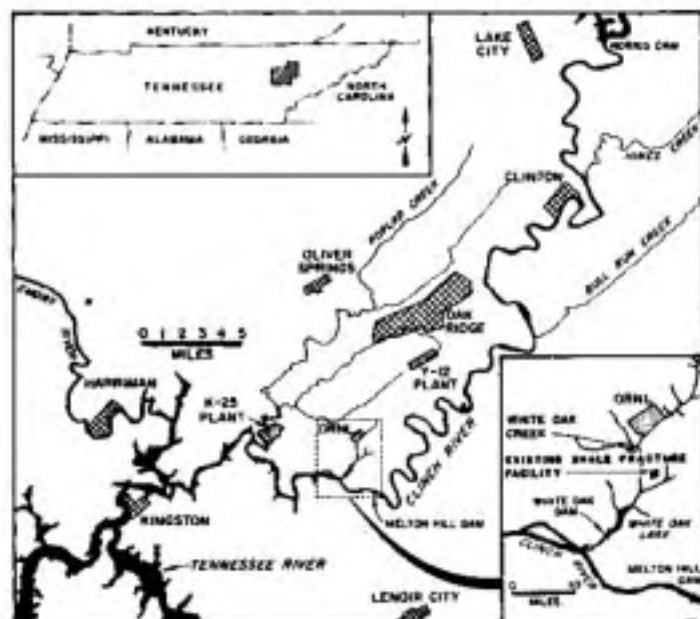

Figure 33 Map of the Oak Ridge Reservation and Vicinity

In the fall of 1942 the Army's Manhattan Engineer District began to acquire 92 square miles (59,000 acres) at Site X at a cost of about \$2,600,000. One small part of this parcel was set aside for residential use and became known as the City of Oak Ridge. The remaining land became the Oak Ridge Reservation. The land comprising the city was sold by the government in the 1950s, and subsequently the city of Oak Ridge was incorporated.

The primary mission of Site X (the Oak Ridge Reservation) was the production of U-235, which was obtained by two separation methods: the gaseous diffusion method at the K-25 site and the electromagnetic separation method at the Y-12 site.<sup>3</sup> The first plutonium production reactor, designated X-10, was built at the X-10 site—now the site of the Oak Ridge National Laboratory (ORNL).<sup>4</sup> It served as a model for the operation of the larger graphite reactors (plutonium production reactors) constructed at the Hanford Reservation.

During the Manhattan Project the Y-12 plant was operated by Tennessee Eastman Corporation, the gaseous diffusion plant at K-25 was operated by the Union Carbide Corporation, and X-10 (now ORNL) was operated first by the Metallurgical Laboratory of the University of Chicago and then (after 1 July, 1945) by Monsanto Chemical Corporation.

1 Initially (1942) known as Site X (disguised under the name "Kingston Demolition Range"); officially designated as the Clinton Engineer Works in early 1943; subsequently (during the 1940s) the entire reservation was designated the "City of Oak Ridge."

2 A second site, selected at Hanford, Washington (see Hanford Reservation) was known as Site W, while the third, code named Site Y, was selected outside Santa Fe, New Mexico (see Los Alamos National Laboratory).

3 A third effort for obtaining U-235 through a thermal diffusion method was authorized in 1944. Although plant facilities were completed for this process, it was later discontinued. A fourth method of separation, the countercurrent process, was originally considered but later

rejected on grounds of cost, complexity, and lack of promise. Ultimately, U-235 produced at Oak Ridge (all that was available) was used as the fissile material in LITTLE BOY, the first nuclear weapon dropped on Japan at Hiroshima. See Vincent G. Jones, *Manhattan: The Army and the Atomic Bomb*, U.S. Army Center of Military History (Washington, DC: GPO, 1985) and Charles W. Johnson and Charles O. Jackson, *City Behind A Fence* (Oak Ridge, Tennessee, 1942-1945). (Knoxville: the University of Tennessee Press, 1981).

4 At the time, reactors were referred to as "atomic piles" and plutonium production reactors were called "plutonium piles." X-10, later called the Oak Ridge Graphite Reactor, is now a historical site.



## Oak Ridge Reservation

Union Carbide took over the management of Y-12 in 1947 and ORNL in 1948. Union Carbide also managed the Paducah, Kentucky, gaseous diffusion plant beginning in 1950. In April 1984 management of all of the Oak Ridge facilities (including the Paducah gaseous diffusion plant) passed to Martin Marietta Corp.

In 1942 the Stone and Webster Corporation, a prime contractor in the plant areas, was given responsibility by the Manhattan Engineer District for development of the township of Oak Ridge. Skidmore, Owings and Merrill designed the town; Stone and Webster was the prime construction contractor.

### Nuclear Weapons Activities

The weapons activities are carried out primarily at the Y-12 Plant (see Y-12 Plant). The Oak Ridge Gaseous Diffusion Plant (GDP) at the K-25 site, which operated until 1985 when it was placed on standby, supplied enriched uranium for civil power and research reactors and for national defense programs.

### Nonweapon Activities

Nonweapons research on the reservation is principally in the development of energy technologies and is conducted primarily at the Oak Ridge National Laboratory (ORNL).

### Facilities

There are three major industrial research facilities on the Oak Ridge Reservation:

1. The Oak Ridge Gaseous Diffusion Plant (GDP) and the gas centrifuge research and development facilities, all at the K-25 site (see Uranium Enrichment Complex)
2. The Oak Ridge National Laboratory (ORNL) at the X-10 site (see below), and
3. The Y-12 Plant at the Y-12 site (see below).

Other areas on the Reservation include:

- The Comparative Animal Research Laboratory (CARL) (not engaged in nuclear weapon activities)
- The Oak Ridge National Environmental Research Park (NERP)
- A 1364-acre southwest portion of the reservation was transferred to the custody of TVA as the site for the proposed Clinch River Breeder Reactor, which was terminated in 1983. The current proposed use of the site is as an industrial park. DOE has proposed to use this site for the Monitored Retrievable Storage (MRS) facility that would perform spent fuel preparation and packaging activities prior to emplacement in a geological repository.

### Management

The Oak Ridge Reservation is a GOCO site, managed for DOE, as of 1 April 1984, by Martin Marietta Energy Systems, Inc., a subsidiary of Martin Marietta Corp. The previous contractor was the Union Carbide Corporation Nuclear Division (UCCND). Martin Marietta (and previously UCCND) operates for DOE the ORNL, Y-12, and the Oak Ridge GDP at Oak Ridge and the Paducah GDP at Paducah, Kentucky. Oak Ridge Associated Universities (ORAU) operates the CARL, at Oak Ridge, for DOE and the Medical Division Programs at ORNL. The Oak Ridge Operations Office administers the Martin Marietta and ORAU contracts.

### Operating Cost and Fees

Union Carbide in its final contract received an \$8 million management fee for managing four facilities at an operating cost of about \$2 billion annually. The replacement contractor, Martin Marietta, will operate with a cost-plus-award-fee contract arrangement with a base fee of \$12 million that will reportedly earn Martin Marietta as much as \$19 million annually.<sup>5</sup>

### PERSONNEL:

Date	Oak Ridge Reservation Employment <sup>6</sup>	Oak Ridge Township Population <sup>6</sup>
May 1945	82,000 (peak)	75,000 (peak)
Nov 1945	51,000	52,000
Jan 1946	43,000	48,000
Jun 1946	34,000	43,000
1950	?	30,205

End FY <sup>7</sup>	Y-12	Oak Ridge GDP	ORNL	Other <sup>8</sup>	Total
1971	6838	2750	4439	-	14024
1972	6413	2763	4361	-	13537
1973	6131	3077	3937	-	13145
1974	5423	3490	4262	-	13175
1975 (Sep)	4718	3849	4910	-	14477
1976	4959	3872	5060	-	15729
1977	5054	6153	5463	-	16670
1978	5242	6273	5006	-	17521
1979	5456	6377	5700	-	17533
1980	5716	6001	5817	-	17534
1981	6057	5236	5852	-	17145
1982	6725	4327	5149	-	16201
1983	5043	4313	5115	332	10703
1984	7155	3963	5102	413	16633
1985 (Mar)	7213	3469	5045	427	16154

<sup>5</sup> Nuclear News, January 1984, p. 23.

<sup>6</sup> Johnson and Jackson, City Behind A Fence, pp. 185-6.

<sup>7</sup> DOE, GOCO Employment, Computer printout for Office of Industrial Relations, R-5529360-012, 29 August 1985.

<sup>8</sup> Includes Lockwood Greene Engineering, Rust Engineering Co., and Science Applications.



## Oak Ridge National Laboratory (ORNL)<sup>1</sup>

<b>ADDRESS:</b>	Oak Ridge National Laboratory P.O. Box X Oak Ridge, TN 37831 615/576-5454 (OR Operations Office) 615/574-4160 (ORNL Public Relations)
<b>LOCATION:</b>	Oak Ridge Reservation X-10 site on 10,270 acres
<b>MISSION:</b>	A broad based multiprogram institution whose principal mission is to carry out applied research and engineering development in fission, fusion, and other energy technologies and conduct scientific research in basic physical and life sciences. Nuclear weapons activities represent a very small fraction of the ORNL research effort.
<b>MANAGEMENT:</b>	GOCO facility operated for DOE by Martin Marietta Energy Systems, Inc.
<b>ESTABLISHMENT:</b>	Established 1942 as part of Manhattan Project.
<b>BUDGET:</b>	\$391.1 million, total lab funding (FY 1986)
<b>PERSONNEL:</b>	5045 (March 1985)
<b>FACILITIES:</b>	Major nonweapon facilities for both basic science and fusion research. <i>Basic Science:</i> • High Temperature Materials Laboratory • Hotifield Heavy Ion Research Facility • High Flux Isotope Reactor • Transuranium Processing Plant • Electromagnetic Isotope Separations Facility (Calutrons) • Oak Ridge Electron Linear Accelerator • Neutron Scattering Facility • Atomic Physics EN-Tandem Accelerator

- Ion-Solid Interactions Laboratory
- National Center for Small-Angle Scattering Research
- SHARE Microanalysis Facility
- Oak Ridge Research Reactor
- High Level Radiochemical Laboratory
- High Radiation Level Examination Laboratory
- Environmental Sciences Laboratory
- Health Physics Research Reactor
- Fusion Energy:
- Impurity Studies Experiment (ISX-B) Tokamak
- International Fusion Superconducting Magnet Test Facility (IFSMIF, formerly known as the Large Coil Test Facility (LCTF))
- Advanced Toroidal Facility (ATF-1) scheduled for 1986
- Elmo Bumpy Torus (EBT-B) proof-of-principle (scheduled 1987)

### History

The Oak Ridge Reservation was established in 1942 as part of the Manhattan Project (see Oak Ridge Reservation). By early 1943, Clinton Laboratories (now ORNL) had been set up to engage in plutonium research, and construction had begun there on a pilot plant to gain experience in plutonium production and chemical separation, prior to full-scale operation of facilities at Hanford.<sup>2</sup> The Clinton pile<sup>3</sup> (originally designated X-10), the first true plutonium production reactor, started operating on 4 November 1943.<sup>4</sup> Built by duPont and designed for a thermal power of 1000 kilowatts, the air-cooled, graphite-moderated, and natural uranium fueled reactor soon exceeded design goals, operating at 1800 kilowatts and higher after May 1944.<sup>5</sup>

The plutonium separation plant at the Clinton Laboratory site received its first batch of irradiated slugs from the Clinton pile in December 1943. By February 1944 the plant was receiving one-third ton of fuel per day, and by March 1944 several grams of plutonium had been separated for research purposes.<sup>6</sup> The separation plant consisted of a series of adjacent cells with thick concrete walls, forming a continuous structure—a "canyon"—100 feet long and two-thirds submerged into the ground.

<sup>1</sup> During the Manhattan Project it was referred to as Clinton Laboratories (for the nearby town of Clinton, Tennessee), or X-10. The Manhattan Project code name X-10 was derived from the intersection of map coordinates X and 10. Briefly during the 1970s it was called the Hotifield National Laboratory.

<sup>2</sup> Because of time and design the Clinton pile was not particularly useful as a pilot plant for the first Hanford reactors. The chief weakness of the Clinton plant is the Manhattan Project was the development of the methods of operation for plutonium recovery. Even the Hanford recovery cells were far along to construction when Clinton was ready. Henry

DeWitt Smyth, *Atomic Energy for Military Purposes*, Princeton University Press, 1945, p. 142.

<sup>3</sup> Subsequently called the Oak Ridge Graphite Reactor.

<sup>4</sup> Smyth, *Atomic Energy*, p. 142. It operated until 1963.

<sup>5</sup> *Ibid.*, p. 143, 144.

<sup>6</sup> *Ibid.*, pp. 112, 144.

Work was performed by remote control behind thick shields.<sup>7</sup> This canyon was the model for future processing plants.

### Nuclear Weapons Activities

ORNL conducts several activities for DOE Defense Programs. The major effort is in three areas: (1) management of wastes generated at ORNL, (2) development of technology for managing low-level and transuranic radioactive wastes, and (3) materials production involving administration of the national repository for U-233 and conversion of 100 kg of uranium from a liquid to an inert solid. ORNL also conducts research on verification and control technology. This work focuses on the development of improved equipment and methodology for isotopic analyses of elements of interest to arms control verification and safeguards (e.g., plutonium, uranium, and thorium).

Although a non-weapon activity, the ORNL U-233 Program is a responsibility of the Office of Nuclear Materials Production. The U-233 program encompasses several tasks, including U-233 scrap recovery and operation of the U-233 National Repository, and installation and operation of a facility to convert 1000 kg of uranium (U-235/U-233 in solution) from liquid to solid (Consolidated Edison Uranium Solidification Program to be completed in FY 1987) The ORNL Materials Production program is also responsible for the DOE inventory of Am-241 and in FY 1986 the Californium Industrial Sales/Loan Program will be transferred from the Savannah River Laboratory to ORNL (see below). Since FY 1985 ORNL has been pursuing several initiatives as part of the President's Strategic Defense Initiative. These efforts focus on the design, development, and evaluation of space-based power systems, the development of negative particle sources with directed energy applications, and support in the development of radiation-hardened, passive optical components.

### Nonweapon Activities

The principal ORNL program activities are in nuclear power development and magnetic fusion research. ORNL also plays an important role in other areas of energy research including conservation, fossil fuels, biomedical and environmental sciences primarily as they relate to energy production. Approximately seven percent of the ORNL effort is in support of the NRC. ORNL performs work for DOD and other federal agencies. ORNL research for the Army primarily involves physical, chemical, and toxicological characterization of chemicals. For the Navy ORNL conducts R&D and performs analyses related to data systems improvement, instrumentation, materials, fuel supply and use, energy

conservation, and waste disposal. Air Force activities include the development of new mathematical algorithms appropriate to pipeline, vector, and array processors, the study of swift atom-solid collisions, hazardous waste site assessments, preparation of radioluminescent lights for remote airfields, and development of selection criteria for insulating materials.

ORNL is engaged in the manufacture, production, and sale of radioactive and stable isotopes that are not available from the private sector. This activity was originated in 1946. It includes the sale of tritium (in gram quantities) and byproduct materials (e.g., californium) produced at Savannah River.

### Management

ORNL is a GOCO facility, operated for DOE, as of 1 April 1984, by Martin Marietta Energy Systems, Inc. The previous contractor was the Union Carbide Corporation Nuclear Division (UCCND). The Oak Ridge Operations Office administers the ORNL contract for DOE under the supervision of the Director of the Office of Energy Research. During its initial Manhattan Project history, Clinton Laboratories (now ORNL) was managed by the Metallurgical Laboratory of the University of Chicago. Monsanto Chemical Corporation took over the management on 1 July 1945, followed by Union Carbide in 1948.

### LAB ACTIVITIES BY PROGRAM (FY 1985):<sup>8</sup>

DOE	
Energy Research	41%
Nuclear Energy	10%
Conservation & Renewable Energy	6%
Defense (Waste Programs)	9%
Other DOE	9%
NRC	7%
DOD	11%
Other Agencies	7%

<sup>7</sup> Ibid., p. 143.

<sup>8</sup> Oak Ridge National Laboratory, Institutional Plan, FY 1985-FY 1991; percentages reflect direct staff (full-time equivalents); p. 23.

BUDGET <sup>9</sup> (\$ million):	FY	Total ORNL Operating	Defense Programs (ASDP) Operating	PERSONNEL: <sup>11</sup>	End FY	Total Personnel
	1971	107.0			1971	2750
	1972	107.6			1972	2783
	1973	110.3			1973	3077
	1974	113.9			1974	3490
	1975	148.2	1.9		1975 (Sep)	4849
	1976*	229.1	3.6		1976	5872
	1977	224.8	7.5		1977	6333
	1978	256.7	11.3		1978	6275
	1979	314.1	13.8		1979	6177
	1980	369.8	21.3		1980	6031
	1981	384.9	19.7		1981	5236
	1982	334.6	22.5		1982	4527
	1983	380.0	32.4		1983	4313
	1984	353.6	35.7		1984	5102
	1985	393.6	37.4		1985 (Mar)	5045
	1986	391.1	42.4			

\* 1976 was a 15-month fiscal year.

#### ASSETS

Capital Investment Equipment estimated to be \$540 million.<sup>10</sup>

<sup>9</sup> Oak Ridge Operations Office, 25 February 1982; Data through FY 1980 from DOE Major National Laboratories Funding Table, January 1981; Oak Ridge National Laboratory Institutional Plan, FY 1982-87, December 1981; Figures 1981-86 Estimated costs from DOE, FY 1980 Budget Request Estimates for Labs/Plants, Office of the Controller, 22 February 1980, pp. 64-70.

<sup>10</sup> DOE, Capsule Review of the DOE Research and Development and Field Facilities, DCID ER-2082, September 1980, p. 17.

<sup>11</sup> DOE, GOCD Employment, Computer printout for Office of Industrial Relations, R-3519369-012, 29 August 1982.

## Y-12 Plant



**Figure 34** Aerial View of Y-12 Plant

**ADDRESS:** Y-12 Plant  
P.O. Box Y  
Oak Ridge, TN 37831  
615/576-5454 (Information)  
615/576-1000 (Assistance)

**LOCATION:** The plant is situated in Bear Creek Valley at the eastern boundary of the Oak Ridge Reservation. The Y-12 Plant site contains a total of 3420 acres, the inner industrial plant complex covers 600 acres, surrounded by buffer of approximately 2820 acres<sup>1</sup>

**MISSION:** The Y-12 Plant has four principal missions:

- Production and fabrication of weapons components and subassemblies, including parts and test devices for the weapon design laboratories
- Processing of source and special nuclear materials
- Support of the three other plants operated for DOE by Martin Marietta Energy Systems, Inc.
- Support of other federal agencies

<sup>1</sup> Environmental Assessment, Y-12 Plant Site, Oak Ridge, Tennessee, U.S. DOE, DOE/EA-0182, December 1982.



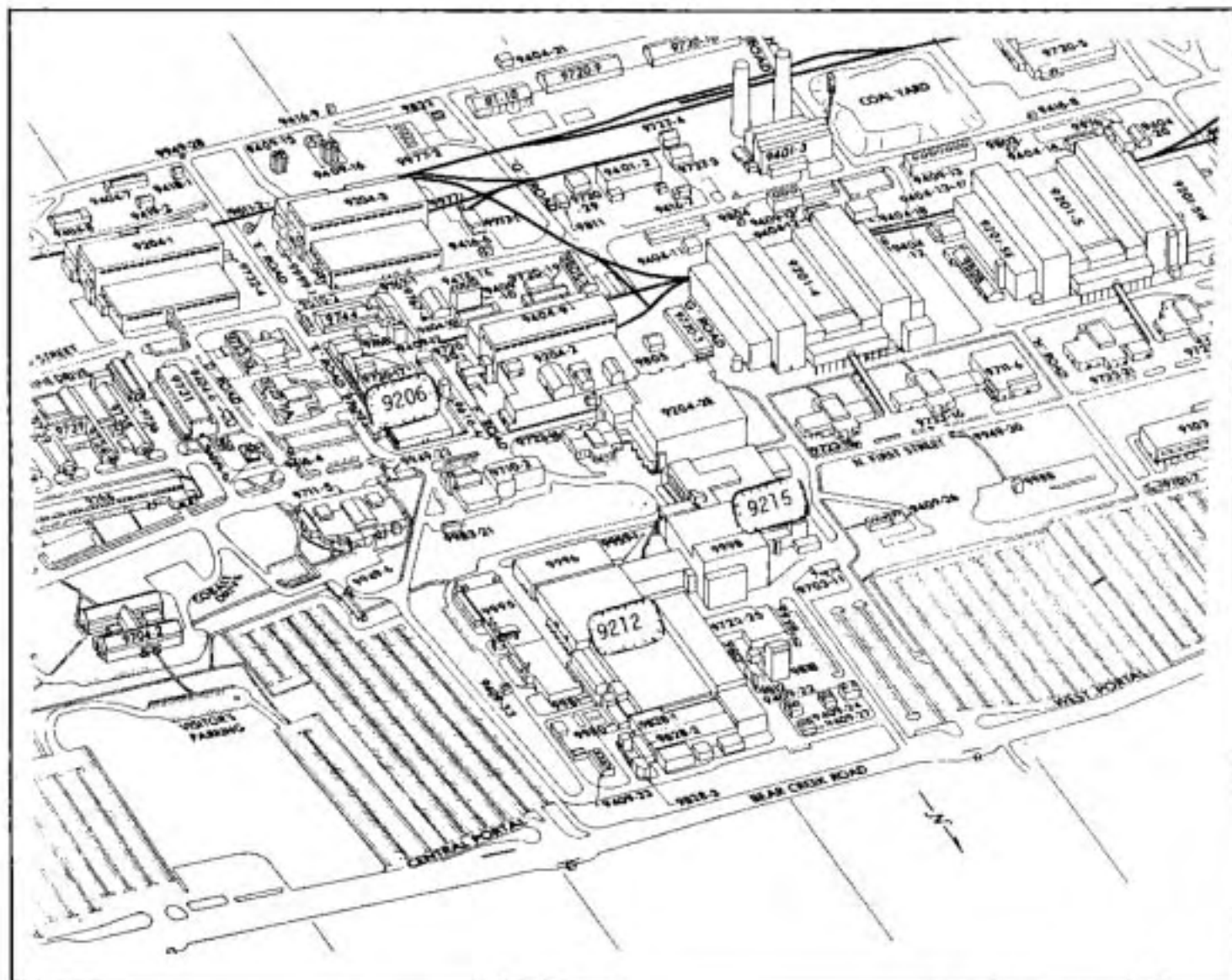

**Figure 35** Location of Facilities at the Y-12 Plant

**MANAGEMENT:** GOCO facility operated for DOE by Martin Marietta Energy Systems, Inc. Contract administered by the Oak Ridge Operations Office acting for the Albuquerque Operations Office

**ESTABLISHMENT:** First production building put into use 27 January 1944

**BUDGET:** \$602.4 million, (FY 1986)

**PERSONNEL:** 7213 (March 1985)

**FACILITIES:**

- Chemical processing buildings
- Large machine shops
- Laboratories
- Maintenance buildings
- Support facilities

## Y-12 Plant



**Figure 36** Enriched Uranium Button



**Figure 37** Filament Winding on Reentry Body

### BUDGET<sup>2</sup> (\$ million):

FY	Total Y-12	Defense Programs ASDP
1971	142.0	104.1
1972	129.5	111.0
1973	118.9	105.3
1974	103.8	90.3
1975	103.8	92.0
1976*	136.5	104.2
1977	149.5	118.2
1978	159.7	123.2
1979	159.0	123.1
1980	200.0	158.8
1981	249.5	203.9
1982	394.0	270.0
1983	370.2	369.4
1984	455.4	442.1
1985	539.9	539.7
1986	602.4	602.1

\* 1976 was a 15-month fiscal year.

### ASSETS

The Y-12 plant and auxiliary facilities include approximately 300 buildings plus several disposal sites. Capital investment and equipment, \$671.0 million (FY 1980).

<sup>2</sup> Outlays: Oak Ridge Operations Office, 25 February 1983; Figures 1986-86 Estimated costs from DOE, FY 1986 Budget Request Estimates for Labs/Plants, Office of the Controller, 22 February 1985, pp. 98-99.

Table 7  
**Estimated Receipts of Recycle Materials at the Y-12 Plant (kg U)**

<u>Fiscal Year</u>	<u>SRP</u>	<u>ICPP</u>	<u>Total</u>
1953	0	101	101
1954	0	217	217
1955	3	828	831
1956	0	744	744
1957	201	797	998
1958	258	898	1156
1959	270	3741	4011
1960	6395	769	7164
1961	2305	0	2305
1962	2701	775	3476
1963	6461	0	6461
1964	2977	771	3748
1965	3546	425	3971
1966	3467	1408	4875
1967	2604	0	2604
1968	2067	394	2491
1969	4121	427	4548
1970	2045	108	2153
1971	3805	1660	5465
1972	4716	415	5131
1973	5051	563	5614
1974	4599	0	4599
1975	5110	1702	6812
1976 <sup>a</sup>	4320	195	4515
1977	4487	1333	5830
1978	2070	525	2595
1979	4591	535	5126
1980	1510	0	1510
1981	4918	905	5823
1982	5728	577	6305
1983	6682	1041	7723
1984	5776	2868	8644
<b>TOTALS</b> (FY 1953-84)	<b>102,824</b>	<b>24,722</b>	<b>127,546</b>

<sup>a</sup> Includes the 3-month transition quarter.

Source: DOE, Oak Ridge Operations Office, "The Report of the Joint Task Force on Uranium Recycle Materials Processing," DOE/OR-858, 1985, p. 43.

#### PERSONNEL:

<u>End FY</u>	<u>Total Personnel</u>	<u>End FY</u>	<u>Total Personnel</u>
Jan 1944:	13,500 <sup>3</sup>	1978	5242
1945:	22,000 <sup>4</sup>	1979	5456
1971 <sup>5</sup>	6835	1980	5716
1972	6413	1981	6257
1973	6131	1982	6725
1974	5423	1983	6943
1975 (Sep)	4718	1984	7155
1976	4759	1985 (Mar)	7213
1977	5054		

<sup>3</sup> ERDA, "Oak Ridge Operations," p. 26.

<sup>4</sup> Charles W. Johnson and Charles G. Jackson, *City Behind A Fence*, Oak Ridge, Tennessee, 1947-1948. (Knoxville: The University of Tennessee Press, 1981), p. 24.

<sup>5</sup> DOE, *GOO Employment*, Computer printout for Office of Industrial Relations, R-552909-012, 29 August 1985.

## Lithium Enrichment Facility

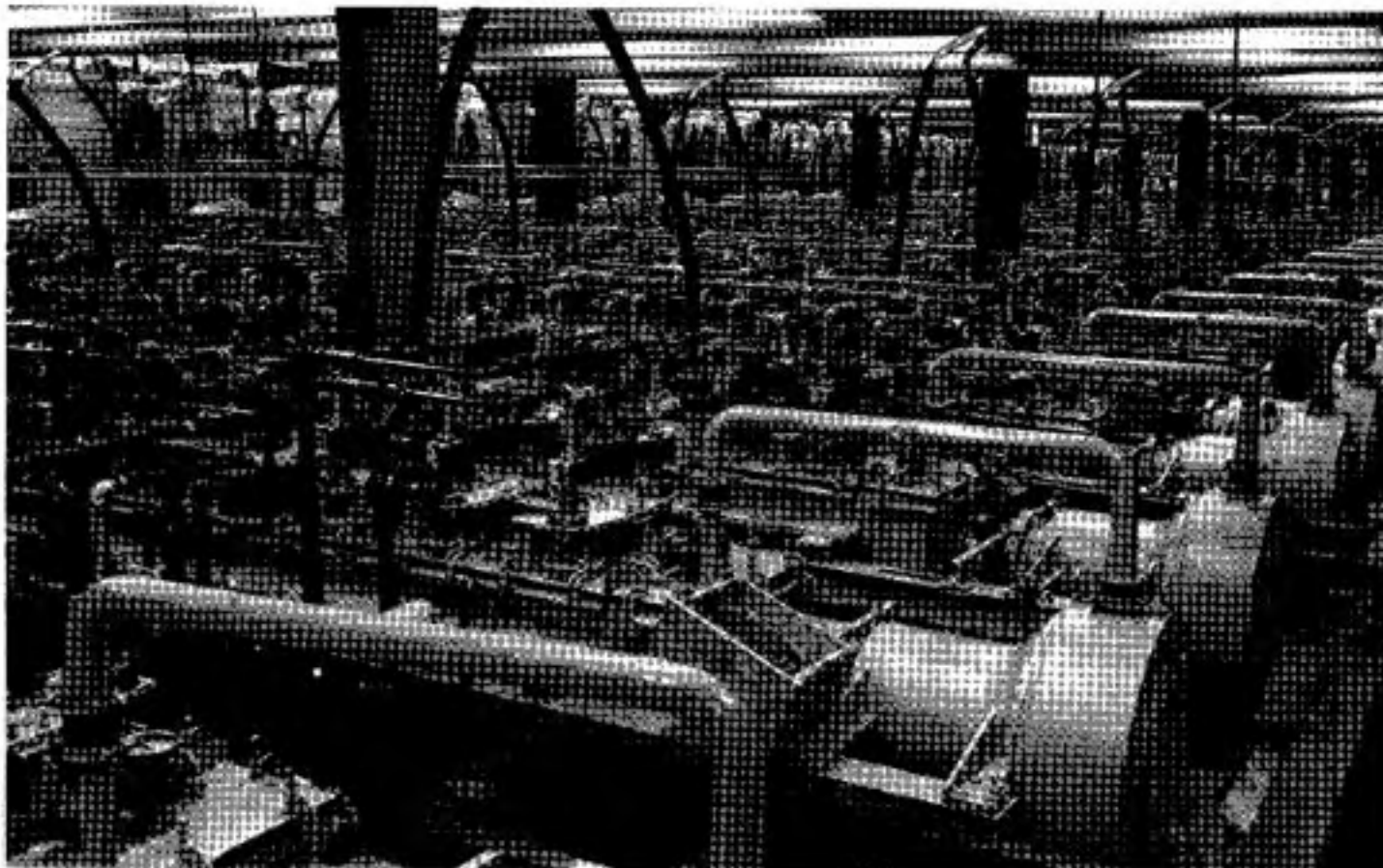

Figure 38 Lithium Enrichment Facility

**ADDRESS:** (see Y-12 Plant)

**LOCATION:** Y-12 Plant

**MISSION:** Separations operations for the large-scale production of lithium-6 (enriched lithium) for the thermonuclear weapons program.

**ESTABLISHMENT:** 1950.

### Lithium Enrichment Plants

AEC-owned facilities for lithium enrichment were constructed and operated at the Y-12 plant in the 1950s and early 1960s. The first lithium enrichment facility, a demonstration plant, went into operation at Y-12 in 1950. Large scale lithium separation activities took place between 1950 and 1963 utilizing a total of eight demonstration, pilot, and production plants. The plant also pro-

duced 99.97 to 99.99 percent pure Li-7 for commercial sale. Production ceased in 1963, with the remaining plant placed on cold standby.

**Chronology:**<sup>1</sup>  
**1950, 1951:** Operated building 9733-2 development facility for Elex (Electrical Exchange) Process

**1951, 1952:** Operated building 9733-1 development facility for Orex (Organic Exchange) process.

**Sep 1951 thru 1955:** Operated building 9201-2 pilot plants for Elex Process and Colex (Column Exchange) Process.

**Apr 1953 thru May 1955:** Operated building 9201-2 pilot plant for Orex Process.

1. *Monthly Inventory of Y-12 Plant 1950 through 1977 (Unclassified Version).* Union Carbide Nuclear Division, Oak Ridge, TN, June 1977.



<b>1953 thru Spring 1956:</b>	Operated building 9204-4 Elex Production Plant.
<b>Jan 1955 thru Feb 1959:</b>	Operated building 9201-5 Colex Production Plant.
<b>Dec 1962 thru May 1963:</b>	Resumed partial operation of 9201-5 Colex Plant for a lithium-7 production run. Produced several thousand kilograms of 99.99% Li-7 for public sale. <sup>2</sup>
<b>1965, 1966:</b>	Building 9201-5 (Colex Production Plant) stripped of process equipment.
<b>Jun 1955 thru Dec 1962:</b>	Operated building 9201-4 Colex Production Plant (similar in design to 9201-5).
<b>Mar 1957 thru May 1962:</b>	Operated building 81-10 facility to recover mercury from solid wastes, primarily lithium carbonate and powdered graphite filter solids.
<b>1963 to Present:</b>	Plant (probably 9201-4) on cold standby.
<b>Feb 1984:</b>	DOE requests funds to decommission lithium enrichment facility.

### Schedule

The plant (probably building 9201-4 Colex Plant) is in "standby" condition: "Y-12 will continue to maintain the lithium enrichment plant in standby as sufficient lithium inventory currently exists."<sup>3</sup> DOE has requested funding (FY 1985 Budget Request) to decommission the lithium enrichment facility.<sup>4</sup>

### Process Description

The Colex Process was ultimately the one used in the lithium production plants at Y-12. It involves the separation of lithium isotopes (lithium-6 from lithium-7) by exchange between lithium amalgam and an aqueous solution of lithium hydroxide. The lithium-7 is concentrated in the amalgam phase.<sup>5</sup> Large quantities of mercury were required for operation, particularly during the years 1955 through 1958.

<sup>2</sup> AEC, Report to Congress, January 1964, p. 43.  
<sup>3</sup> HAC, FY 1985 EWDA, Part 4, p. 257.

<sup>4</sup> HAC, FY 1985 EWDA, Part 4, p. 234.  
<sup>5</sup> Mason Benedict, Thomas H. Pigford and Hans Wolfgang Levi, *Nuclear Chemical Engineering* (New York: McGraw Hill, 1961), pp. 638, 641, 661.

## Pantex Plant (Amarillo Plant)



Figure 39 Aerial View of Pantex Plant

<b>ADDRESS:</b>	Mason and Hanger-Silas Mason Co. Inc. P.O. Box 30020 Amarillo, TX 79177 806/381-3000 (DOE Field Office) 806/381-3802 (Mason and Hanger)	tion, and quality assurance testing of nuclear weapons already in the stockpile, and (3) disassembly of nuclear weapons retired from the stockpile.
<b>LOCATION:</b>	Carson County, Texas, about 17 miles northeast of Amarillo and 16 miles west of Panhandle, Texas, on north side of Highway 60; 9100-acre site	<b>MANAGEMENT:</b> GOCO facility operated for DOE by Mason and Hanger-Silas Mason Company, Inc., of Lexington, Kentucky; under management of the Albuquerque Operations Office
<b>MISSION:</b>	Manufacture of high explosive (HE) components for nuclear weapons, and the final assembly and the disassembly of nuclear weapons. As an assembly facility it performs three major operations: (1) production of new nuclear weapons for delivery to DOD, (2) maintenance, modifica-	<b>ESTABLISHMENT:</b> 1942 (Pantex Army Ordnance Plant); 1951 (Pantex Ordnance plant operated by AEC); September 1963 (complete control transferred to AEC)
		<b>BUDGET:</b> \$198.1 million (FY 1986)
		<b>PERSONNEL:</b> 2749 (March 1985)



Figure 40 Map Showing Location of Pantex Plant

#### FACILITIES:

- High Explosives Fabrication and Weapon Assembly/Disassembly facilities
- Temporary Holding facilities for HE and weapons
- High Explosive Research and Development Area
- Firing Sites for HE quality assurance tests and HE R&D
- Burning Ground for disposing of scrap HE
- Inert Assembly and Test Facility (FY 1986)
- A radiographic bay housing an 8 MeV linear accelerator

#### History

The Pantex Army Ordnance Plant was constructed in 1942 and during World War II was operated by the Army Ordnance Corps as a conventional ammunition shell and bomb loading facility. It was closed in 1945 and all production equipment removed. In 1949 the 14,954-acre installation was transferred by the War Assets

Administration to Texas Tech University for use as an agriculture station. However, in 1950 the AEC decided to duplicate operations at its Iowa Ordnance at Burlington (used for nuclear weapons operations 1947-1975) and in 1951 selected the Pantex location for this purpose. A portion of the original Pantex site and the existing facilities were returned to the government, and in 1951 the AEC began operation of the Pantex Ordnance Plant as a chemical explosives fabrication and nuclear weapon assembly plant. By late 1952 extensive construction and rehabilitation activities were completed.

The Army had responsibility for high explosive fabrication at both Pantex and Burlington prior to 1963. Direct control of all operations and facilities at the two sites was transferred to the AEC in September 1963, and their names were officially changed to the Pantex Plant and the Burlington AEC Plant.

In the 1960s and 1970s operations at the plants in Clarksville, Tennessee, and Medina, Texas, and at the Burlington Plant were consolidated at Pantex.

#### Nuclear Weapons Activities

Pantex fabricates the non-nuclear high explosive (HE) components of nuclear weapons. It assembles these together with prefabricated nuclear and non-nuclear components, received mainly from the other DOE plants of the warhead production complex, into finished nuclear weapons.<sup>1</sup> Pantex also assembles inert or mock nuclear weapons used in firing test programs and drop test programs. These Joint Test Assemblies (JTAs) contain no fissile material and no significant quantity of high explosive but otherwise approximate a war reserve weapon. A JTA unit is comprised of war reserve weapon components, plus one or more subassemblies (such as telemetry units) substituted for critical components.

New chemical HE materials are not usually produced at Pantex but are purchased from the Army or commercial suppliers and processed at Pantex in manufacturing operations such as casting, pressing and machining to components of the desired density and shape. Pantex does manufacture and assemble stock HE components for DOE and DOD testing and training programs.

The Pantex Plant also conducts research and development work on high explosives to support weapon design and development programs at the DOE weapon laboratories. No nuclear materials are involved.

#### Facilities

The manufacturing area contains more than 100 buildings. It has facilities for mixing, pressing, and machining high explosive (HE) materials into desired solid shapes, as well as for the machining of plastics and metals. In early years, most of the HE parts were formed by casting after the HE had been melted by steam. With progress in weapon design and production technology, HE fabrication gradually evolved from molten-casting to

1 DOE, PEGS, Pantex Plant Site, DOE/EIS-0098, October 1983.

## Pantex Plant



Figure 41 Aerial View of Assembly Bays

precision machining of the explosive shapes needed in newer weapons.<sup>2</sup>

Subassembly operations involve HE preparation, the mating of two or more HE parts, or joining of HE parts to a case or liner. These operations, which involve exposed HE but no radioactive materials, are conducted in "subassembly bays"—square reinforced concrete rooms, separated and covered by earth and designed to prevent an explosion from causing a sympathetic explosion in an adjacent bay. Typically, a subassembly bay is designed to provide for up to 300 lb HE in each bay.<sup>3</sup> There are twenty-four subassembly bays at the Pantex Plant (March 1984).<sup>4</sup>

In "assembly cells" the HE parts are mated with fissile nuclear components of a nuclear implosion weapon, and the entire HE/nuclear material unit is encased in a protective shell or liner, generally stainless steel, aluminum, or titanium. The entire encased unit is called a "physics package." The cells (called "Gravel Certies") are designed to prevent the spread of radioactivity. All weapons assembly work involving exposed HE and radioactive material is conducted in assembly cells. There are nine assembly cells in operation (seven built in the 1950s and 1960s, two just completed, and four under construction (March 1984)). In an assembly bay, components are added to the physics package to complete the assembly of a weapon. Assembly bays, structurally similar to subassembly bays, are designed to vent through the roof and withstand pressure from an explosion in adjacent bays.

Beginning in the third quarter of FY 1987 a total of forty subassembly bays will be required. Based on future



Figure 42 Igloos at Pantex

weapon production workload projections (beyond FY 1987), it is anticipated that a total of sixty subassembly and assembly bays will be required to support a five-day-per-week, two-shift-per-day operation. Therefore, site planning for the sixteen subassembly bays will include provisions for a 36-unit complex.<sup>5</sup>

The reliability assurance program for nuclear weapons and the research and development work on high explosives for DOE require laboratory facilities for destructive and nondestructive testing. This work employs techniques for accelerated aging of materials, neutron radiography, measurement of chemical and physical properties, and test firing.

The Temporary Holding area is a safe and secure place for high explosives and nuclear materials not being worked on. "Igloos" (earth-covered, bunker-like structures) temporarily hold the high explosives and nuclear weapons (see Figure 42).

FY 1983 funding was requested for a radiographic bay with an 8MeV linear accelerator and a damaged and disabled weapons disassembly facility.<sup>6</sup>

### Management

Pantex is a GOCO facility operated for DOE by Mason and Hanger-Silas Mason Company, Inc., of Lexington, Kentucky. The Office of Military Application under the ASDP is responsible for the program direction. This responsibility has been delegated to the Albuquerque Operations Office, which also administers the DOE contract with Mason and Hanger-Silas Mason. Mason and Hanger-Silas Mason performed the rehabilitation of the portion of the old Pantex Army Ordnance Plant in

2. HAC, FY 1985 EWDA, Part 4, p. 251.

3. *Ibid.*, p. 214.

4. *Ibid.*, p. 215.

5. *Ibid.*

6. HAC, FY 1983 EWDA, Part 4, pp. 190-3.



1951 (see History, above) and the Army Ordnance Corps contracted the services of Procter and Gamble Defense Corp. to operate the plant initially. Mason and Hanger-Silas Mason was selected by the Army Ordnance Corps to operate the plant on 1 October 1956.

BUDGET <sup>7</sup> (\$ million):	DOE Defense Programs	
	FY	
	1981	79.3
	1982	140.3
	1983	131.8
	1984	147.3
	1985	190.4
	1986	198.0

**ASSETS** Capital investment and equipment, \$102.9 million (FY 1980). The facilities at the Pantex Plant include some 288 buildings totaling approximately 1.5 million square feet of floor space (1976).<sup>8</sup>

**PERSONNEL:<sup>9</sup>**

FY (end)	Pantex	Burlington
1971	1697	1106
1972	1748	1105
1973	1743	1133
1974	1817	689
1975 (Sep)	1896	closed
1976	1792	
1977	1820	
1978	1889	
1979	2100	
1980	2225	
1981	2306	
1982	2517	
1983	2603	
1984	2732	
1985 (Mar)	2749	



Figure 43 Assembly Bay at Pantex

7 Outlays; Figures 1984-86 Estimated units from DOE, FY 1986 Budget Request Estimates for Labs/Plants, Office of the Controller, 22 February 1985, p. 2.

8 ERDA, Environmental Assessment Pantex Plant, June 1976, p. 1-7.

9 DOE, OIGD Employment, Computer printout for Office of Industrial Relations, W-5329309-012, 29 August 1985.

## Pinellas Plant



Figure 44 Aerial View of Pinellas Plant

<b>ADDRESS:</b>	General Electric Company Neutron Devices Department P.O. Box 2908 Largo, FL 34294 813/541-8173	<b>ESTABLISHMENT:</b>	Construction began in 1956, with production operations in 1957
<b>LOCATION:</b>	Central Pinellas County, about midway between St. Petersburg and Clearwater, Florida; 96.9 acre site	<b>BUDGET:</b>	\$138.6 million (FY 1986)
<b>MISSION:</b>	Manufacture neutron generators and other special electronic and mechanical components of nucle- ar weapons	<b>PERSONNEL:</b>	1926 (March 1985)
<b>MANAGEMENT:</b>	GOCO facility operated for DOE by General Electric Company (Nu- clear Division), under manage- ment of Albuquerque Operations Office	<b>FACILITIES:</b>	<ul style="list-style-type: none"><li>• Ultra-high vacuum tube processing</li><li>• Thin metallic film evaporation- deposition-hydriding</li><li>• High-voltage subcomponents printed circuit boards and other electronics manufacturing</li><li>• Ceramic metalizing</li><li>• High-voltage encapsulation</li><li>• Glass working</li><li>• Specialty brazing</li><li>• Assembly, testing, and resin en- capsulation facilities for high voltage components</li></ul>

### Nuclear Weapons Activities

The Pinellas Plant is responsible for the production of components for nuclear weapons. Such components include neutron generators and their associated power supplies, thermal batteries, specialty capacitors and switches, and other special electrical and electronic components. The generators are designed at Sandia Laboratories. They are about the size of a fist, and are used to initiate the fission chain reaction in nuclear weapons. Neutron generator development was formerly carried out by GE in Milwaukee, but in 1966 these activities were transferred to Pinellas.<sup>1</sup>

Pinellas also manufactures neutron detectors, radioisotopically powered thermoelectric generators (RTG) using heat sources of plutonium typically encapsulated in metal (each capsule containing a few grams of plutonium-238 oxide) produced at the Mound Laboratory, lightning arrestor connectors to protect nuclear weapons in the field from lightning, thermopiles, specialty capacitors and switches, and sophisticated product testers.

All activities at Pinellas are related to the production of nuclear weapons.

### Facilities

The processing of tritium (tritium is used in neutron generators) and the handling of encapsulated Pu-238 heat sources are involved in making some end products that are produced in relatively small quantities. These products generally require highly developed technologies and must meet high quality standards.

Manufacturing technologies at Pinellas include ultra-high vacuum tube processing, thin metallic film evaporation-deposition-hydriding, high-voltage subcomponents, printed circuit boards and other electronics, ceramic metalizing, high-voltage encapsulation, glass working, and specialty brazing. There are facilities for assembly, testing and resin encapsulation of components to withstand high voltage operation. Thermoelectric generators are assembled in glove boxes to protect against leakage of plutonium and provide a super dry environment.

### Management

The Pinellas Plant is a GOCO facility operated for DOE by the General Electric Company (Nuclear Division). Construction of the Pinellas Plant by the General Electric Company was begun in 1956 and 1957. Shortly thereafter the AEC exercised an option to purchase the plant from GE, which continued to operate the plant as a GOCO facility. The Office of Military Application under the ASDP is responsible for program direction. This responsibility has been delegated to the Albuquerque Operations Office, which also administers the DOE contract with GE.

BUDGET <sup>2</sup> (\$ million):	FY	DOE Defense Programs
	1981	61.9
	1982	80.8
	1983	94.0
	1984	122.8
	1985	137.9
	1986	138.6
ASSETS	Capital investment and equipment, \$388.0 million (FY 1980). Nine buildings cover almost 400,000 square feet.	
PERSONNEL: <sup>3</sup>	End FY	Pinellas (GE)
	1971	1260
	1972	1243
	1973	1224
	1974	1220
	1975 (Sep)	1109
	1976	1123
	1977	1202
	1978	1260
	1979	1435
	1980	1520
	1981	1786
	1982	1762
	1983	1841
	1984	1918
	1985 (Mar)	1926

<sup>1</sup> AEC, Report to Congress, January 1967, p. 124.

<sup>2</sup> Challeys; Figures 1984-86 Retained from DOE, FY 1980 Budget Request Estimates for Lab/Plants, Office of the Comptroller, 22 February 1980, p. 72.

<sup>3</sup> DOE, GOCO Employment, Computer printout for Office of Industrial Relations, B-5528209-012, 20 August 1980.

## Rocky Flats Plant

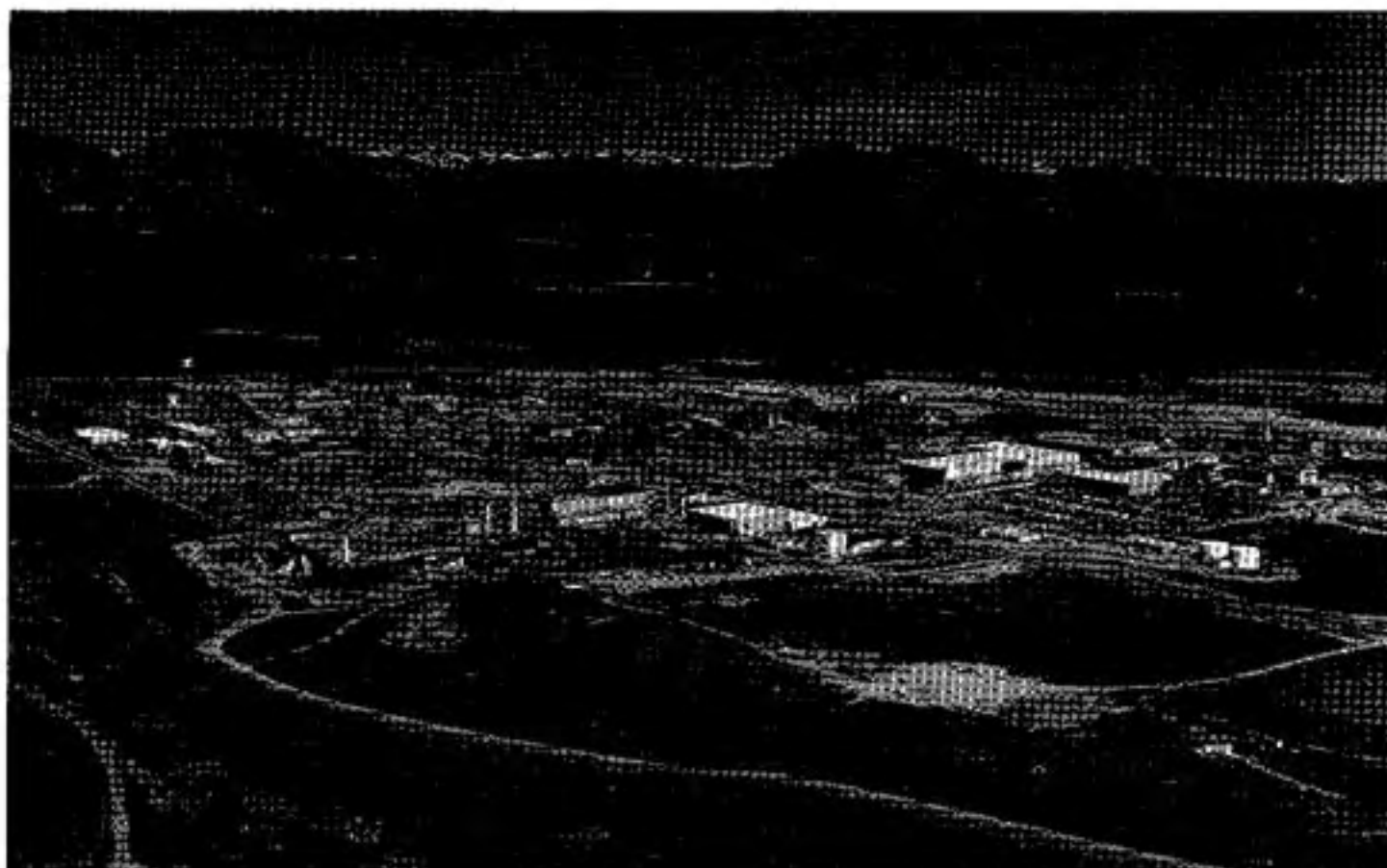

Figure 45 Aerial View of Rocky Flats Plant

Source: DOE

**ADDRESS:** Rockwell International  
Energy Systems Group  
P.O. Box 464  
Golden, CO 80401  
303/966-7000  
303/966-7883 (Public Affairs)

**LOCATION:** Between Golden and Boulder,  
Colorado, about 21 miles north-  
west of Denver; 6551-acre (11-  
square-mile) site

**MISSION:** Fabrication, assembly, and quality  
testing of radioactive and  
nonradioactive components, in  
the pits<sup>1</sup> of nuclear weapons

**MANAGEMENT:** GOCO facility operated for DOE  
by Rockwell International, under  
management of the Albuquerque  
Operations Office

**ESTABLISHMENT:** Plant construction began 1951 and  
operations began 1952.

**BUDGET:** \$484.9 million (FY 1986)

**PERSONNEL:** 5991 (March 1985)

**FACILITIES:** Numerous facilities for plutonium  
processing and plutonium, urani-  
um, and beryllium fabrication

### Nuclear Weapons Activities

At Rocky Flats all plutonium fabrication, pit assembly, surveillance, and pit disassembly following retirement is conducted for the nuclear warhead production complex. Rocky Flats also has sole responsibility within the integrated production complex for recovery of plutonium and americium (by chemical processing) from weapon retirement and fabrication-process residues (scrap). The plant is engaged primarily in metal produc-

<sup>1</sup> The "pit" is that part of an implosion-type fission weapon or fission trigger of a thermonuclear weapon inside the chemical high explosive material.



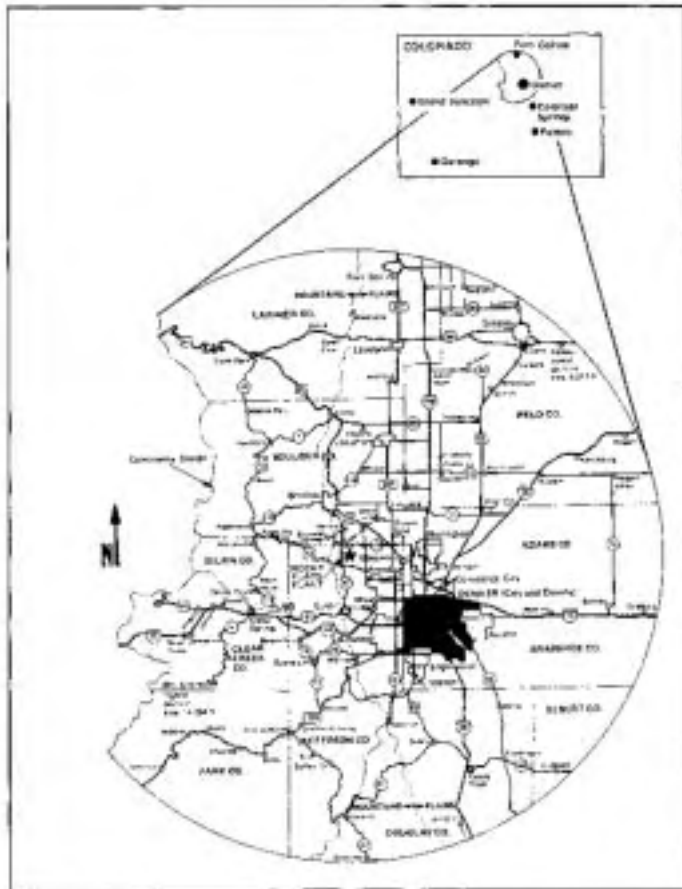

Figure 46 Location of Rocky Flats Plant within a 50-mile radius

tion and chemical processing, with heavy emphasis on production-related research. Production activities include fabrication of plutonium and uranium alloy and the fabrication and assembly of conventional metal components.

Rocky Flats manufactures the plutonium parts of nuclear warhead cores, uranium and beryllium tampers, and special stainless steel components, including tritium reservoirs (storage bottles) and other nuclear warhead components.<sup>2</sup> The plant fabricates other component parts of beryllium metal, plus the thin shells/cans to contain plutonium parts and other nonfissionable metallic pit components. The plant also fabricates depleted uranium components (tampers) and has the capability to fabricate components of enriched uranium and U-233. It fabricated some HEU components until mid-1965 when these activities were transferred to the Y-12 plant where similar work was being done.

The plant conducts applicable research and provides development support to the weapon laboratories in its area of expertise. Emphasis is placed on specialized areas of technology, such as plutonium materials, pro-

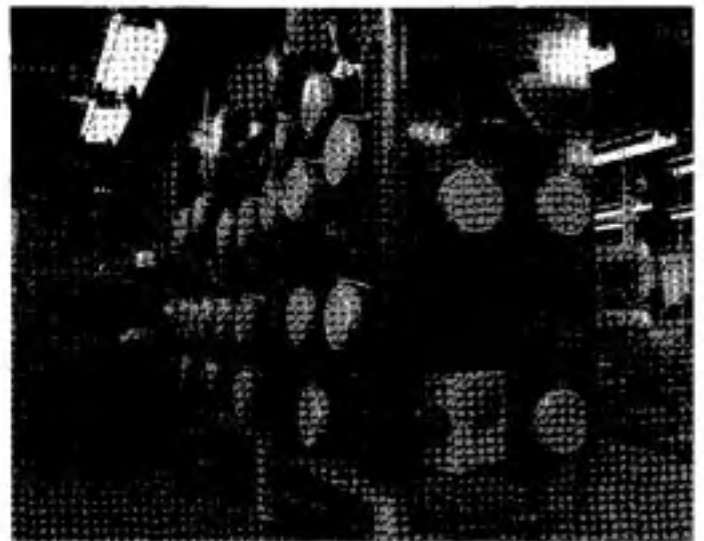

Figure 47 Glove Box Area, Rocky Flats Plant

cesses, and handling, for which the plant is uniquely equipped.

### Facilities

Plutonium ingots are processed through metallurgical operations involving reduction, rolling, blanketing, forming and heat treating. Chemical operations include purification of plutonium and beryllium (scrap recovery) and a unique capability for extracting and purifying americium-241 from plutonium for shipment to an isotope storage and distribution center in Oak Ridge for subsequent industry-wide use. A new Plutonium Recovery and Waste Treatment Facility at Rocky Flats began production in March 1982. Plutonium scrap generated at Rocky Flats and all plutonium from weapons retirements is processed in this facility.

Plutonium processing and metal production is conducted in a multi-building complex centered around Buildings 371, 771, and 776. Building 371 (formerly referred to as the Plutonium Recovery Facility) conducts electrorefining (pyrochemical plutonium metal purification), calcination of direct oxide reduction feed, and a variety of packaging, storage, and nondestructive assay activities. Building 371 also houses a new aqueous process which has not operated satisfactorily. Building 771 conducts aqueous processing, provides primary recovery and purification of plutonium residues, nondestructive assays, and a variety of packaging, research and development, and laboratory activities. Building 776 conducts pyrochemistry processing—purification of plutonium via pyrochemistry—americium removal, plutonium oxide reduction to metal, and waste packaging and incineration activities. Building 374 and 774 are liquid waste processing facilities associated with Buildings 371 and 771, respectively.

<sup>2</sup> Tritium reservoirs are loaded at the Savannah River Plant.

## Rocky Flats Plant



**Figure 48** Handling Plutonium "Button" in "Dry Box"

Plutonium processing and fabrication is generally conducted in glove boxes.<sup>3</sup> Plutonium ingots and parts are stored in closed containers in vaults. Fabrication of warhead components includes subcomponent forming and joining, plus inspection and verification testing of finished components. A new hot isostatic press for beryllium technology applications, for pressing special shapes and for bonding dissimilar metals was requested (FY 1985 budget).<sup>4</sup>

Equipment exists for rolling, conventional forming, hydroforming, high-energy-rate forming, extruding, heat treating, shearing, machining, electroplating, and inspecting of many kinds of nonradioactive metals. Non-nuclear manufacturing is performed in two major buildings—Building 881 (Manufacture and General Support Building) and Building 444 (Production Shop).

Specialized support activities at Rocky Flats include accountability, safeguards, health, safety, environmental protection, and waste management.

### Management

The Rocky Flats Plant is a GOCO facility operated for DOE by Rockwell International, which assumed operation of the plant from Dow Chemical on 1 July 1975. The Office of Military Application under the ASDP is respon-

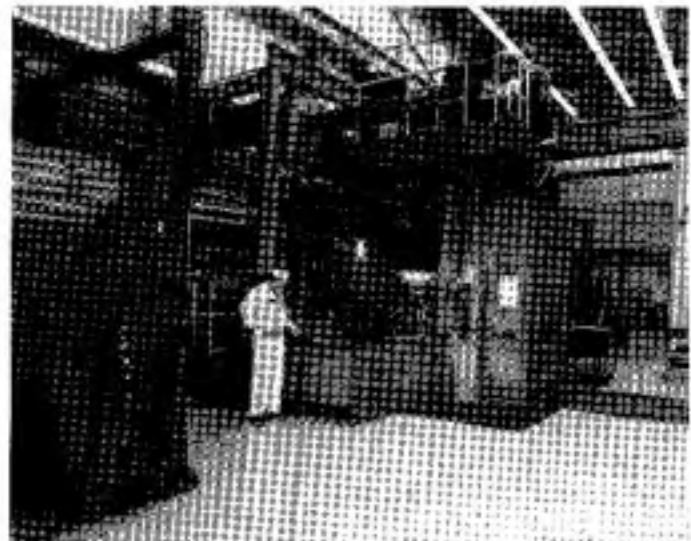

**Figure 49** Beryllium Foundry, Rocky Flats Plant

sible for program direction. This responsibility is delegated to the Albuquerque Operations Office, which also administers the Rockwell contract with DOE.

BUDGET <sup>5</sup> (\$ million):	FY	DOE Defense Programs	Total DOE
	1981	174.7	187.3
1982	240.6	245.6	
1983	308.4	312.9	
1984	394.8	398.3	
1985	465.6	467.7	
1986	484.9	484.9	

### ASSETS

There are more than 2 million square feet of building floor space in over 100 structures at Rocky Flats. Capital investment and equipment, \$422.9 (FY 1980).

<sup>3</sup> DOE, FEIS, Rocky Flats Plant Site, DOE/EIS-0064, April 1980, Volume 1, pp. 2-99 to 2-105.  
<sup>4</sup> EAC, FY 1985 EWOA, Part 4, p. 232.

<sup>5</sup> Outlays: Figures 1984-86 estimated costs from DOE, FY 1986 Budget Request Estimate for Labs/Plants, Office of the Comptroller, 22 February 1985, pp. 51-62.

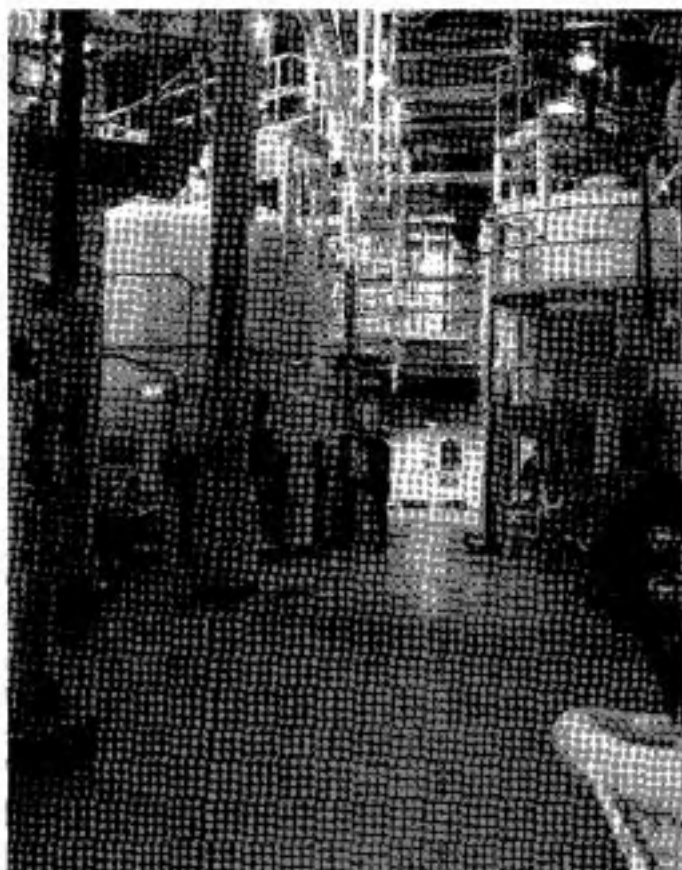

**Figure 50** Plutonium Recovery Area, Rocky Flats Plant.

<b>PERSONNEL:<sup>6</sup></b>	<b><u>End FY</u></b>	<b><u>Rocky Flats</u></b>
	1971	3722
	1972	3568
	1973	3310
	1974	2937
	1975 (Sep)	2783
	1976	2735
	1977	2879
	1978	3209
	1979	3222
	1980	3596
	1981	4095
	1982	4898
	1983	5335
	1984	5867
	1985 (Mar)	5991

<sup>6</sup> DOE, COCO Employment, Computer printout for Office of Industrial Relations, R-5528389-012, 28 August 1985.

## Sandia National Laboratories (SNL)<sup>1</sup>



Figure 51 Aerial View of Sandia National Laboratory Albuquerque

Source: SNL

**ADDRESS:** U.S. Department of Energy  
Sandia National Laboratories  
P.O. Box 5800  
Albuquerque, NM 87185  
505/844-5678  
505/844-8066 (Public  
Information)  
415/422-7011 (Livermore)

**LOCATION:** Laboratories at Albuquerque, New Mexico (SNLA), and Livermore, California (SNLL); also operates Tonopah Test Range (TTR), Nevada. Including Tonopah, Sandia operations utilize over 370,000 acres: 39,500 acres at Albuquerque (3100 acres DOE/Sandia, 11,100 acres co-use with DOE and DOD, 25,300 acres National Forest

Service withdrawal land); 185 acres at Livermore;<sup>2</sup> 369,280 acres at TTR. In 1971 Kirtland AFB and Sandia-Albuquerque merged into one base under Air Force control.

**MISSION:** Multiprogram laboratory with emphasis on research, development and engineering of all components of nuclear weapons systems, except the nuclear explosive components. Sandia takes nuclear devices developed and tested by LANL and LLNL and performs the R&D necessary to incorporate these devices into operational weapons.

Sandia has shared responsibility with LANL and LLNL for the

<sup>1</sup> Formerly Sandia Laboratories.

<sup>2</sup> Plans by FY 1986 are to acquire an additional 388 acres of buffer land surrounding SNLL and LLNL to protect against demonstrations, possible terrorist attacks, and covert surveillance: HAC, FY 1985 EWDA, Part 4, pp. 188-89.





**Figure 52** Map of Albuquerque, Kirtland Air Force Base, and Sandia Laboratories  
Source: SNL

design of every nuclear weapon type now in the stockpile and continues to support both nuclear design labs on each assigned program.

#### MANAGEMENT:

GOCO facility managed for DOE by Sandia Corporation, a wholly owned subsidiary of AT&T Technologies, Inc. (formerly Western Electric Company), under management of the Albuquerque Operations Office

**ESTABLISHMENT:** 1945 (SNLA); 1956 (SNLL)

**BUDGET:** \$1102.6 million, total lab budget (FY 1986)

**PERSONNEL:** 8480 total lab (March 1985)

**FACILITIES:** (see text under *Facilities* heading)

## Nuclear Weapons Activities

In conjunction with the two design laboratories, Sandia is responsible for the research and development associated with weapon engineering for all phases of the nuclear warhead life cycle. Sandia's major priorities in weapon R&D are new weapon engineering development (Phase 3) programs that are currently active and anticipated, and engineering development to improve weapons now in the stockpile. Its responsibilities include the non-nuclear aspects of nuclear weapon ordnance engineering, specifically the design of electrical system safety, arming, fuzing, and firing systems, neutron generators, tritium reservoirs, weapon structures (cases), aerodynamic shapes, parachutes, and other related delivery devices. No weapon manufacturing or assembly is done at Sandia except for research or test purposes; that function is performed by DOE's manufacturing facilities and private industry, using design and processing information provided by Sandia and other weapon laboratories. Sandia designs and develops Joint Test Assemblies (JTAs) that are assembled at Pantex. Its major testing activity, however, is the study of the vulnerability of warheads to nuclear weapon effects.

Sandia also conducts research in nuclear weapon safety, security, and control and is involved in the training of military personnel to assemble and maintain completed weapons. It is the lead laboratory for developing safe and secure transportation systems and secure manufacturing and storage facilities for nuclear weapons.

Sandia supplies radiation hardened, large-scale integrated circuits (computer chips) to the Bendix Plant for use in nuclear weapons. (The 1982 order exceeded 60,000 units.)<sup>2</sup>

In the area of verification and control technology Sandia's programs include the development and deployment of satellite-borne instrumentation to verify compliance with the Limited Test Ban Treaty, the development and evaluation of automated seismic stations that would help verify threshold or comprehensive test bans (the Regional Seismic Test Network deployed at five locations in the United States and Canada beginning in 1982 and the new experimental array in Norway), and the assessment and analysis of foreign weapons and weapon development programs.

Sandia is principal laboratory for R&D on physical protection and for containment and surveillance measures that pertain to DOE facilities subject to international safeguards or to foreign facilities of high national interest.

In the FY 1986 budget the DOE requested money for a Strategic Defense Facility at Sandia planned to be completed in 1991 at a cost of \$70 million. The facility, supporting President Reagan's Strategic Defense Initiative, would house research on directed energy weapons in the form of particle beams, x-ray lasers, microwaves, and kinetic energy.



Figure 53 Aerial View of Sandia National Laboratory Livermore

Source: SNLL

Sandia participates in the ICF Program jointly with LLNL, LANL, and their supporting laboratories. It is the lead laboratory for pulsed power development. Sandia's involvement with pulse power fusion grew from military requirements to test weapon components for hardness to nuclear radiation. A high voltage and high current beam striking a high atomic number metal plate produces a burst of x-rays simulating a nuclear blast.

In the 1970s it was recognized that electron beams used for simulation purposes could be concentrated to high enough intensities for ICF research.<sup>4</sup> This research currently concentrates on pulse power accelerators (very high voltage pulses of either electrons or preferably light ions) as fusion drivers and advanced target design. (Target design and DT pellet fabrication is done in collaboration with LANL.)

The near-term goal is to establish the feasibility of ICF using intense ion beams or imploding foils driven directly by pulse-power generators. The program is oriented toward military applications (simulation of nuclear weapons effects) with demonstration fuel ignition a secondary goal. An evaluation of the ICF program is planned in the FY 1987 time frame for further contri-

butions to weapon physics research and possible development as an energy source.

Sandia now generates about 80 percent of the product definitions (component design specifications) used by the warhead production complex. Currently 25 percent of design is computer generated. In FY 1983 Sandia was named lead lab to develop the data base for an integrated CAD/CAM (computer aided design/computer aided manufacturing) network to link all agencies of the warhead complex, replacing diverse and incompatible CAD/CAM systems already in place.

### Other Weapons Activities

Sandia conducts research for the Army, Navy, Air Force, DNA, and DARPA. This work for DOD constitutes almost 13 percent of Sandia's budget. The work for the Army involves upgrading security at NATO nuclear weapon sites, including the Weapons Access Delay and Intrusion Detection System. For the Navy the work is to develop an integrated arming, fuzing, and firing system for the TRIDENT II/Mk 5 reentry vehicle. For the Air Force work involves developing radiation-hardened electronics, sensors, and ground data-processing systems

4. "Particle Beam Fusion," Sandia Laboratories.



Figure 54 Site Map of Sandia National Laboratory Livermore

for satellite programs. A second project is RADLAC-2, a joint Sandia-Air Force Weapons Laboratory program to assess the feasibility of electron beams as short range weapons for close-in terminal defense. The RADLAC-2 accelerator is the most powerful electron beam accelerator in the United States. For DNA Sandia provides explosively actuated closure doors for use on weapons effects tests at NTS. The DARPA is supporting exploratory development and flight evaluation to investigate feasibility of using Sandia-developed maneuvering reentry vehicles as advanced interceptors.

### Nonweapon Activities

Sandia conducts research and development in nuclear safety and alternative energy programs, including nuclear reactor, fuel, and nuclear waste management (e.g., sub-seabed disposal), solar power research, and electron-beam fusion and laser development. Research on alternative energy systems includes engine combustion, solar thermal power, solar photovoltaic conversion, and wind energy. Although Sandia is primarily an engineering laboratory, it also supports research in the physical sciences.

Sandia has a large computer complex, including two CRAY-1 (one at Albuquerque, one at Livermore) and two

CDC 7600s.<sup>5</sup> Sandia will acquire a Class VII computer in 1987 or 1988.<sup>6</sup>

### Facilities

Numerous facilities are used to conduct a wide range of research activities. SNLA has several pulsed and steady state reactors (SPR-I, II, and III, ACPR, and ACRR) used in R&D of neutron radiation-hardened weapon systems, and several x-ray and gamma-ray sources (Rehyd, Hydra, Proto II, and Hermes II) used to simulate weapons effects.

*Simulation Technology Laboratory (STL).*<sup>7</sup> (SNLA, construction ends FY 1987.) STL will house the Hermes III accelerator, an advanced gamma-ray simulator, and the Particle Beam Fusion Accelerator-I (PBFA-I), modified as an advanced x-ray simulator. There weapons effects facilities will, in some instances, have capabilities comparable to underground testing. STL facilities will test hardness of future nuclear weapons systems (e.g., MX, TRIDENT II); will offer means to study vulnerability to directed energy devices, the propagation of high-intensity particle beams and the physics of x-ray lasing; and will improve the ability to simulate threats that generate dose-rate-dependent radiation effects.

Hermes III, an advanced gamma-ray simulator, under construction, will deliver a 0.6 million joule pulse of e-beam energy to a bremsstrahlung converter target, a factor of 10 in performance over the existing Hermes II.

PBFA-I and PBFA-II, while used for weapons effects research, are part of the Inertial Confinement Fusion (ICF) Program.

*Particle Beam Fusion Accelerator-I (PBFA-I).* PBFA-I, an advanced x-ray simulator, is the first modular pulsed power generator. First operated in 1980 and built at a cost of \$14 million, PBFA-I consists of 36 modules arranged like spokes of a wheel around a fusion pellet target chamber centrally located in the wheel's hub. Each module contains an energy storing Marx generator and a pulse forming/voltage conditioning section. The voltage pulse of each module is converted to a burst of ions in a single diode at the wheel's hub. The ions in turn are directed toward the target at the center. Operating at 2 million volts, PBFA-I produces a 40 nanosecond wide pulse delivering 0.5 million joules of energy and 30 trillion watts of power to electron or light ion sources. PBFA-I is engaged in ion beam fusion and radiation effects experiments using electron beams. There has been significant conversion of pulse power to x-rays.<sup>8</sup> Research consists of ion beam focusing experiments with the objective of 5 trillion watts/cm<sup>2</sup> and DT pellet target studies.

*Particle Beam Fusion Accelerator-II (PBFA-II).* PBFA-II is an upgraded pulsed power particle beam accelerator system, configured like PBFA-I, which began operation in December 1985. PBFA-II is a 108-foot diame-

<sup>5</sup> HASC, FY 1985 EWDA, Part 6, p. 227; SNLA Institutional Plan FY 1984-1988, pp. 32-33.  
<sup>6</sup> A Class VII computer is defined as one having at least four times the computing capacity of a CRAY-1.

<sup>7</sup> HASC, FY 1985 EWDA, Part 4, pp. 191-94.  
<sup>8</sup> HASC, FY 1983 DOE, p. 130.



ter wheel 20 feet in height, housing thirty-six particle accelerators. PBFA-II is designed to operate at 4 million volts and deliver a 40 nanosecond pulse with approximately 3.5 million joules of energy and 100 trillion watts of peak power to light ion sources, providing power pulses at target of 50 trillion watts/cm<sup>2</sup>. PBFA-II will operate initially with lithium ions rather than protons.<sup>9</sup> Plans are to conduct DT fusion ignition scaling experiments. Like PBFA-I, it will principally benefit studies for military applications.<sup>10</sup>

The Center for Radiation-hardened Microelectronics at SNLA provides SNLA with an in-house capability to design and fabricate large-scale integrated circuits and conduct research for DOD and DOE in high-temperature and microwave electronics, and on radiation hardened micro- and opto-electronic circuits.

The Radiation-Hardened Integrated Circuit Laboratory (LSI Facility) at SNLA, established 1974, develops radiation-hardened large-scale integration (LSI) circuit technologies and designs for electronic packages of nuclear warheads (e.g., W78, W81, W82, B83, W84, B61-6,-7,-8). This facility was designed to provide a backup production source in the event the U.S. semiconductor industry cannot satisfy DOE production needs. SNLA does significant production for DOE (Bendix Plant acquired 5000 chips and packaged integrated circuits in 1981, orders exceeded 60,000 units in 1982), for DOD, and other agencies. Responsibility for operation of LSI clean room is currently being transferred to Bendix.

The Radiation-Hardened Integrated Circuit Laboratory (LSI Facility)<sup>11</sup> at SNLA, is scheduled to be completed in FY 1987 at a cost of over \$40.5 million. The facility will develop the next generation of very-large-scale integrated (LSI) circuit technologies to meet more complex requirements of 1990s in weapon capability, accuracy, command and control, safety, and security.

A wide range of other research facilities exist. These include, for example:

- Lightning Facility (SNLA).<sup>12</sup>
- Rocket Sled Test Track (SNLA). 5000 ft test track; extended track to 10,000 feet by December 1984
- Safeguards Light Laboratory (SNLA, completed FY 1980)
- Weapons Laboratory Building (SNLL, construction ends FY 1987, cost \$20.4 million). To support state-of-the-art R&D in electronics, applied physics, and materials science for application to components of nuclear weapons.<sup>13</sup>
- Instrumentation Systems Laboratory (SNLA, construction FY 1986-88, cost \$20 million). Major technical programs to be located in this facility include: (1) development of telemetry systems to support weapon JTA and flight evaluations, especially TRIDENT II; (2) weapon/aircraft compat-

bility evaluations (the B1-B and B61-6,8); (3) satellite instrumentation system development associated with nuclear-burst treaty verification and monitoring; and (4) new SDI instrumentation for tracking, focusing, orientation, and damage assessment

- Facilities to study solid state materials. The Combustion Research Facility (SNLL) contributes to the solution of combustion science problems
- Facilities at the Pantex Plant for quality assurance test operations
- Reactor facilities to simulate effects inside power reactors

### SNLA Technical Areas.<sup>14</sup>

SNLA is divided into five major technical areas on Kirtland Air Force Base (plus remote test sites on undeveloped and mountainous terrain covering more than 50 square miles).

Area I: Primary laboratory area; 100 acres; 100 buildings housing majority of technical and administrative staff, laboratories, test facilities, fabrication and assembly areas; large volume of classified information and material; small quantities of nuclear and radioactive materials.

Area II: Remote 300-acre area; 40 buildings and storage igloos housing facilities for testing and storing explosive devices.

Area III: Remote 1900-acre environmental test area; some 50 buildings housing flash x-ray facilities<sup>15</sup> and numerous other test facilities unique to development testing of nuclear weapons.

Area IV: Particle Beam Fusion (PBF) research; 250-acre plot with approximately 12 buildings.

Area V: Sandia Reactor Facility; some 15 buildings on 20 acres, housing various reactors and a dosimetry laboratory;<sup>16</sup> large quantities of special nuclear materials and other radioactive materials.

### Management

Sandia is a GOCO facility managed for DOE by Sandia Corporation, a wholly owned subsidiary of AT&T Technologies, Inc. (formerly Western Electric Company), which is a subsidiary of the American Telephone and Telegraph Company. Sandia Laboratory at Albuquerque was operated by the University of California from 1948 until 1949, when at the request of President Truman the Bell System assumed responsibility for managing the facility, and the contract was taken over by the Western Electric Company. Since 1949 Sandia Laboratories has been operated under a no-fee, no-profit contract basis. The Office of Military Application under the ASDP is responsible for technical direction, while the Sandia contract is administered by the Albuquerque Operations Office.

9. HAC, FY 1985 EWDA, Part 4, p. 212.

10. *Ibid.*

11. HAC, FY 1985 EWDA, Part 4, p. 154.

12. HAC, FY 1985 EWDA, Part 4, p. 167.

13. *Ibid.*, pp. 121-22.

14. HAC, FY 1985 EWDA, Part 4, p. 172.

15. *Ibid.*, p. 105.

16. *Ibid.*



**LAB ACTIVITIES  
BY PROGRAM  
(FY 1984):<sup>17</sup>**

Defense Programs	68.0%
Conservation and Renewable Energy	4.5%
Nuclear Energy	0.2%
Fossil Energy	2.0%
Energy Research	2.6%
Work for Others	
Department of Defense	12.6%
Nuclear Regulatory Commission	4.5%
Others	2.5%
Civilian Radioactive Waste Management	2.0%
Other DOE	1.1%

**PERSONNEL:<sup>19</sup>**

<u>End FY</u>	Sandia		<u>Total</u>	<u>Weapons Activities</u>
	<u>Albu- querque</u>	<u>Liver- more</u>		
1971	6307	990	7297	
1972	6237	986	7223	
1973	5529	872	6401	
1974	5609	868	6447	4029(62%)
1975 (Sep)	5652	887	6539	4303(66%)
1976	6060	962	7022	4290(61%)
1977	6273	991	7264	3777(52%)
1978	6471	1007	7478	3754(50%)
1979	6588	1030	7618	3565(47%)
1980	6792	1055	7847	3602(46%)
1981	6935	1083	8018	3584(45%)
1982	6862	1088	7950	3816(48%)
1983	7024	1106	8130	3951(49%)
1984	7326	1101	8427	4053(48%)
1985 (Mar)	7385	1095	8480	4138(49%)

**BUDGET<sup>18</sup>  
(\$ million):**

<u>FY</u>	<u>Total Lab Fund- ing</u>	<u>DOE Defense Programs Total</u>
1983	827.0	525.6(64%)
1984	921.3	588.8(64%)
1985	1011.7	673.0(61%)
1986	1102.6	737.4(67%)

**ASSETS**

Capital Investment and equipment, \$422.5 million (FY 1980). Sandia Laboratories comprises nearly 400 buildings containing some 3.4 million square feet of floor space (2.8 million square feet at Albuquerque, 0.5 million at Livermore and 0.1 million at Topopah).

17 Sandia National Laboratories, Institutional Plan FY 1985-FY 1990, p. 8. Percentages reflect direct full-time equivalent personnel.

18 Sandia National Laboratories Institutional Plan, FY 1984-FY 1989, FY 1985-FY 1990; FY 1986-FY 1991.

19 DOE, GOOD Employment, Computer printout for Office of Industrial Relations, R-0029309-012, 29 August 1985. Percentage for weapons activities based on FTEs from Volume II, Table 2.2.

## Savannah River Plant (SRP)

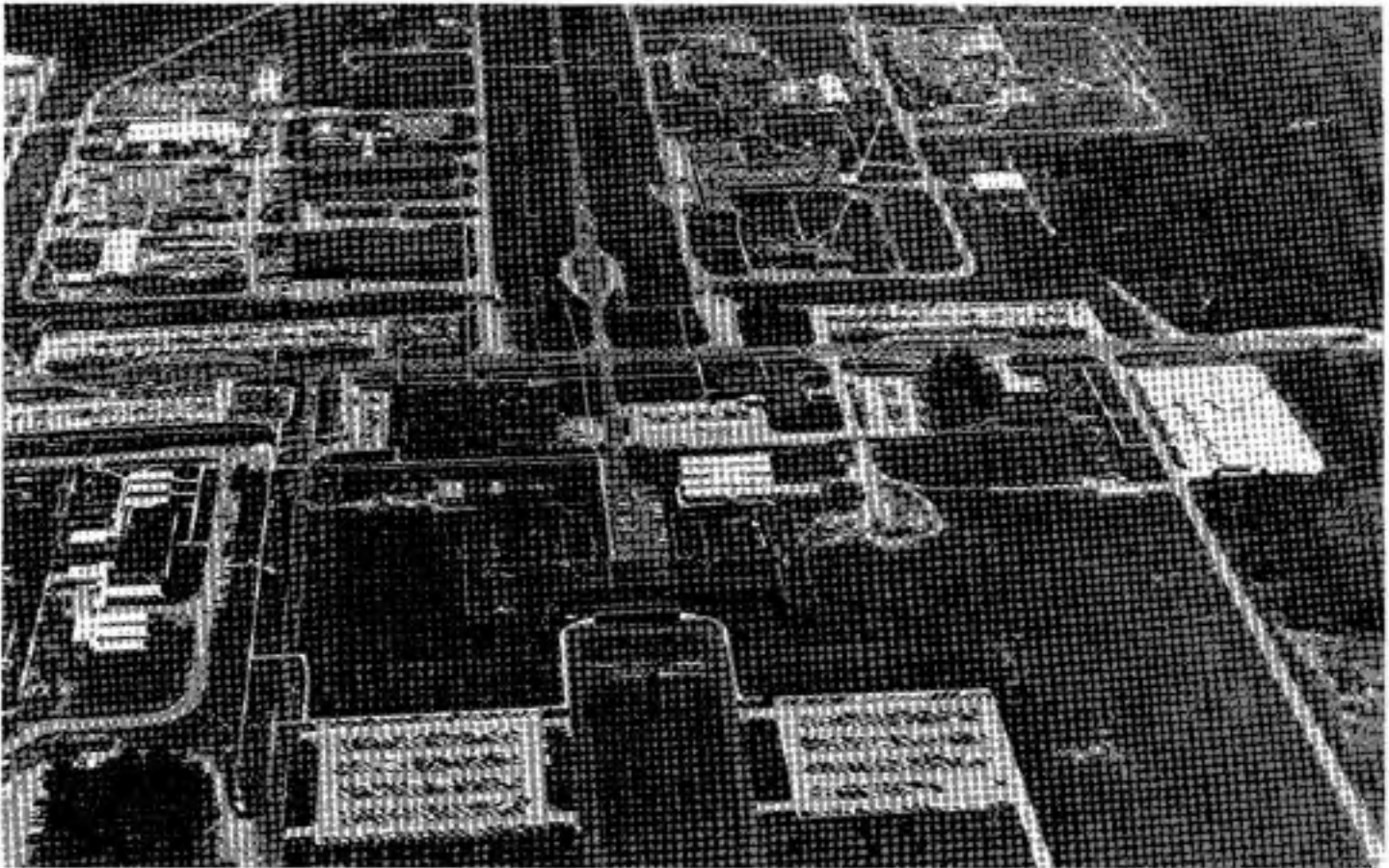

Figure 55 Main Administration Area SRP

**ADDRESS:** U.S. Department of Energy  
Savannah River Operations Office  
P.O. Box A  
Aiken, SC 29802  
803/725-6211

**LOCATION:** 192,323-acre site (300 square miles) spread over three counties in South Carolina (67,512 acres in Aiken County, 120,727 acres in Barnwell County, and 4,084 acres in Allendale County), some 12 miles south of Aiken, South Carolina.<sup>1</sup>

**MISSION:** Production of nuclear materials for nuclear weapons, primarily plutonium, tritium, and heavy water. SRP's mission over the

years has been broadened to include production of small quantities of other radioisotopes<sup>2</sup> and handling nuclear weapon components (filling tritium reservoirs).

**MANAGEMENT:** GOCO facility operated for DOE by E.I. duPont de Nemours and Company under the management of the Savannah River Operations Office

**ESTABLISHMENT:** Site selection 1950, construction temporary facilities 1951; operations begun 1952; construction basic plant finished 1956

**BUDGET:** \$1199.2 million, (FY 1986)

<sup>1</sup> The Savannah River Plant, DCE 58-002, Savannah River Operations Office, Revised 1980, p. 13.

<sup>2</sup> The isotopes Pu-238, U-233, Co-60, Am-241, Cm-244, and Cf-242, are produced primarily for nondefense purposes.

**PERSONNEL:** 15,480 total on-site (end FY 1985)

**FACILITIES:**

- Production Reactors
- Fuel and Target Fabrication Facilities
- Chemical Separation Plants
- Heavy Water Plant and Rework Unit
- Tritium Facility
- Savannah River Laboratory
- Defense Waste Processing Facility (Future)
- Naval Fuels Facility (Future)
- U-236 Production Plant (Future)
- Savannah River Ecology Laboratory
- Aquatic Research Laboratory
- Savannah River National Environmental Research Park

### History

Site selection for a new production facility was begun by the AEC in June 1950 and selection of the (originally) 250,000-acre Savannah River site south of Aiken, South Carolina, was announced by the AEC on 22 November 1950. DuPont was chosen to construct and operate the facilities. Construction of temporary facilities began in February 1951. Operations commenced with the startup of the heavy water plant on 3 October 1952. Construction of the basic plant was completed in 1956 at a cost in excess of \$1.1 billion (including \$18.957 million for the site).

The decision in 1950 to go ahead with SRP was driven by the perceived need for tritium in the fusion weapon program following President Truman's directive of 31 January 1950 to develop a thermonuclear weapon (the "super").<sup>3</sup> While production of tritium in the Hanford reactor (for research at Los Alamos) had been demonstrated, the new plant at Savannah River was necessary to avoid serious curtailment in the production of plutonium at Hanford for the fission program.<sup>4</sup> The heavy water reactors at Savannah River were to be more efficient than the graphite reactors at Hanford, and the design would afford the greatest flexibility for the manufacture of either plutonium or tritium.<sup>5</sup> Even if thermonuclear weapons proved unfeasible or tritium requirements turned out to be less than anticipated, as indeed was the case, the construction of SRP was further justified on the following grounds: to increase plutonium production, to provide a higher efficiency in the use of uranium ore, to provide security against attack of the Hanford reactors, and to be replacement reactors in the event of retirement of older Hanford reactors.<sup>6</sup>

### Nuclear Weapons Activities

#### Nuclear Material Production

SRP produces the major portion of the plutonium and all the tritium required for weapons. (The N-Reactor at Hanford also produces plutonium for weapons.) SRP has also been the sole producer of heavy water in the United States, but the production plant was shut down in early 1982. (See Heavy Water Plant.) SRP is the sole source of heavy water (from stocks), tritium, and Pu-238 in the United States. The Savannah River Laboratory conducts research in a number of areas to support operation of plant facilities (see Savannah River Laboratory).

#### Nuclear Weapon Production

Savannah River's weapon production activities consist of the extraction and purification of tritium from irradiated targets, the loading of tritium components of weapons, and the purification of tritium recovered from retired weapons. To offset a potential interruption in production at the Pinellas Plant, DOE has implemented a program to stockpile certain neutron generator types at SRP.

### Nonweapon Activities

The Savannah River Laboratory conducts research on high level radioactive waste and a variety of support activities for DOE energy technology and enrichment programs. (See Savannah River Laboratory.)

### Facilities

#### Production Reactors

Four heavy-water-moderated production reactors (P,K,L,C) are being operated to produce tritium (predominately in C-Reactor)<sup>7</sup> and super-grade plutonium (predominately in K, L, and P-Reactors). An additional production reactor has been maintained in standby since 1964. The L-Reactor, also on standby from 1968 to 31 October 1985, was scheduled for startup in October 1983 but was held up by Congress and the federal courts for environmental reasons. (For further details see Savannah River Production Reactors.) A small test reactor (V) is in standby condition.<sup>8</sup>

#### Fuel Cycle Facilities<sup>9</sup>

Facilities are operated to fabricate reactor fuel and target elements for use in the onsite production reactors. (See Savannah River Fuel and Target Fabrication Facilities.)

Enriched uranium-aluminum alloy from the Y-12 Plant at Oak Ridge is extruded into tubes of driver fuel for the SRP production reactors. Depleted uranium target slugs from the Feed Materials Processing Center (FMPC) at Fernald are canned in aluminum at SRP and used as targets for plutonium production in SRP production reactors. Enriched lithium (Li-6) from the Y-12 Plant is

<sup>3</sup> Lee Bowen, *A History of the Air Force Atomic Energy Program 1943-1993*, Vol. IV, The Development of Weapons, U.S. Air Force Historical Division, p. 30.

<sup>4</sup> *Ibid.*, p. 32.

<sup>5</sup> *Ibid.*

<sup>6</sup> Statement by AEC Chairman, May 1950, *Ibid.*, p. 32.

<sup>7</sup> HAC, FY 1985 EWDA, Part 4, p. 427.

<sup>8</sup> Control Technology for Radioactive Emissions to the Atmosphere at U.S. Department of Energy Facilities, YNL-4261, Grift, Pacific Northwest Laboratories, March 1983, p. 10-2.

<sup>9</sup> F.K. Drake and R.W. Benjamin, Savannah River Plant Airborne Emissions and Controls, DPST-82-1094, Savannah River Laboratory, DOE Research and Development and Field Facilities, DOE/R 6028, June 1975, p. V-10.

## Savannah River Plant



Figure 56 The Savannah River Plant Site<sup>9</sup>

processed into lithium-aluminum targets for tritium production at SRP.

Irradiated fuel and target elements from Savannah River production reactors and from (offsite) research reactors (domestic and foreign) are processed in two chemical separation plants, F and H (see Savannah River Chemical Separation Facilities).

The Multi-Purpose Processing Facility is used to separate special isotopic materials such as americium-241 and plutonium-238. Heavy Water production at Savannah River has ceased, but the Rework Unit operates to purify D<sub>2</sub>O used in reactors. The Central Scrap Management Office (CSMO) manages the recovered Pu-238 and Pu-239 scrap. This office has a computerized data base for Pu-239 scrap.

### Tritium Facility

Tritium separation, purification, and loading activities are conducted in three major buildings that make up the Savannah River Tritium Facility (see Tritium Recovery under Savannah River Chemical Separations Facilities).

### Savannah River Laboratory

The Savannah River Laboratory provides support for

nuclear material production and other DOE program activities.

### Defense Waste Processing Facility

Construction of the Defense Waste Processing Facility (DWPF) began in October 1983 for scheduled operation in 1989 (estimated cost \$910 million). The DWPF will dissolve and solidify the sludge component of Savannah River high level waste (HLW) in borosilicate glass, encasing the glass in stainless steel canisters (2 feet in diameter and 10 feet high) for dry storage or disposal in geologic repositories. The HLW (some 30 million gallons of liquid, salt cake and sludge) is stored at SRP in single and double shelled stainless steel tanks. DWPF will process about 2 million gallons of waste per year.<sup>10</sup>

### Naval Fuels Facility

A new DOE-owned facility for the production of naval nuclear fuels—the Fuels Materials Facility (FMF)—began construction in late 1983<sup>11</sup> and will be completed at Savannah River in 1986 (estimated cost \$176 million) for operation by duPont in the late 1980s as a backup to the NRC licensed production plant operated by Nuclear Fuel Services at Erwin, Tennessee.<sup>12</sup>

### U-236 Plant<sup>13</sup>

A U-236 Production Plant is scheduled for initial operation at SRP in 1987 with full production to begin in FY 1988.<sup>14</sup> The U-236 Program has been undertaken by DOE-SRP in collaboration with TRW and Lawrence Livermore National Laboratory. The plant will utilize the TRW plasma separation process (PSP) to improve SR reactor productivity by removal of the uranium-236 buildup in recycled fuel as well as removal of the isotopes U-234 and U-238.

The production goal of 2-3 MT of U-235 per year in a ten-year PSP campaign will also provide some 75 percent of Savannah River U-236 requirements (U-236 is used in the production of Pu-238). The U-236 plant will use an existing building at SR adjacent to the enriched fuel tube fabrication building and an existing PSP module, which is production size and has demonstrated U-235/U-236 separation at near production conditions. The building will contain machinery for fabricating separate feed plates. Installation began in FY 1985.

### Management

SRP is a GOCO facility operated for DOE by E.I. duPont de Nemours and Company. Defense activities are administered by the DOE Assistant Secretary for Defense Programs (primarily the Offices of Nuclear Materials Production, Military Application, and Defense Waste and Byproducts Management) through the DOE Savannah River Operations Office. Activities at the Tritium Facility are the responsibility of the Albuquerque Operations

<sup>9</sup> ERDA, Savannah River Operations Office, "Integrated Radioactive Waste Management Plan, Savannah River Plant, Aiken, South Carolina," SRP-RWM-76-1, June 1976.

<sup>10</sup> HASC, FY 1984 DOE, pp. 283-86.

<sup>11</sup> Inside Energy, 22 August 1983, p. 10.

<sup>12</sup> U.S. NRC, In the Matter of Nuclear Fuel Services, Docket No. Q0-143, SNM License No. 124, Department of Energy Response to Questions, 1 March 1983.

<sup>13</sup> Plasma Separation Process, TRW Energy Development Group, Redondo Beach, CA, (undated; May 1982).

<sup>14</sup> HASC, FY 1985 EWDA, Part 4, p. 434.



Office. E.I. duPont de Nemours and Company designed, built and has operated the Savannah River Plant since its establishment in 1950.

Beginning in FY 1985, Wackenhut Service, Inc. assumed responsibility for physical security. In March 1985 approximately 700 personnel were under contract.

**BUDGET (SRP)<sup>15</sup>**  
(\$ million):

<u>FY</u>	<u>Total</u>
1975	213.1
1976	346.1
1977	324.0
1978	393.6
1979	361.3
1980	422.0
1981	520.5
1982	732.2
1983	861.2
1984	1084.5
1985	1394.5
1986	1199.2

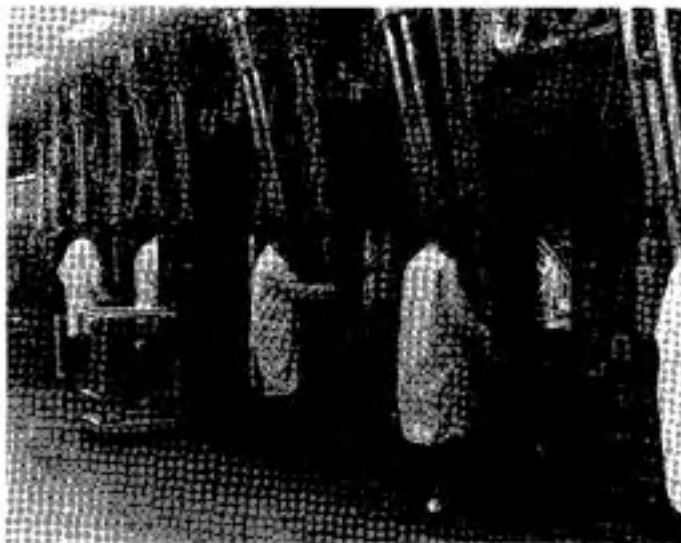

**Figure 57** Master-Slave Manipulators, Savannah River Laboratory

These master-slave manipulators permit handling of radioactive materials by Savannah River Laboratory scientists.

**PERSONNEL:<sup>16</sup>**

<u>End FY</u>	<u>Operations</u>	<u>Construction</u>	<u>On-Site Total</u>
1951	255	8044	8299
1952	1046	35,758	27,129
1953	4684	23,759	28,784
1954	7981	12,327	19,729
1955	8328	3055	11,745
1956	8177	1857	10,584
1957	7181	2247	10,295
1958	6852	1820	9172
1959	6655	596	7573
1960	6535	865	7616
1961	6614	1009	7244
1962	6743	938	7890
1963	6320	851	7681
1964	5679	714	6787
1965	5591	625	6457
1966	5584	530	6331
1967	5622	602	6462
1968	5295	632	6174
1969	5210	573	6037
1970	5138	386	5770
1971	5127	571	5946
1972	5201	627	5979
1973	5250	534	5973
1974	4993	686	6086
1975	5263	1027	6343
1976	5414	1214	6879
1977	5690	1383	7317
1978	5850	1785	7928
1979	5769	1978	7747
1980	6100	1883	7983
1981	6596	2080	8676
1982	6675	1243	9245
1983	6889	3117	11,121
1984	8098	4757	13,459
1985	6647	6055	15,480

<sup>15</sup> "SRP Budget in Second Billion," Aiken Standard, 1 October 1984, p. 10A; SRP Operations Office.

<sup>16</sup> Information provided by DOE Operations Office SRP, January and June 1984 and November 1985. For FY 1982-FY 1985 Operations column excludes SRL, Savannah River Ecology Lab, Wackenhut, DOE, and U.S. Forest Service, but they are included in the Total column.

ogy Lab, Wackenhut, DOE, and U.S. Forest Service, but they are included in the Total column.

## Savannah River Laboratory (SRL)

<b>ADDRESS:</b>	Savannah River Laboratory Aiken, SC 29808 803/725-3422
<b>LOCATION:</b>	700-A area of Savannah River Plant
<b>MISSION:</b>	The Laboratory's primary function is to support the Savannah River Plant (SRP)
<b>MANAGEMENT:</b>	See Savannah River Plant
<b>ESTABLISHMENT:</b>	1951
<b>BUDGET:</b>	\$91.5 million (1986)
<b>PERSONNEL:</b>	1000 total lab (1986)

### History

The Savannah River Laboratory participated in the original design of production facilities at SRP and provided technical assistance during startup operations. Following the startup phase of the production reactors in the 1950s, SRL developed technology that served as the basis for a steady increase in the productivity. Subsequently, attention was turned to developing the techniques to obtain various new products and byproducts, such as U-233, Co-60, Pu-238, Cm-244, and Cf-252. For some products, such as Pu-238 and Cf-252, further development was undertaken to adapt them to various end uses. During the period 1958 to 1964, a laboratory program developed technology for a D<sub>2</sub>O-cooled power reactor operating on natural uranium.<sup>1</sup>

### Nuclear Weapons Activities

Currently, SRL activities are divided about equally between two DOE lead laboratory mission assignments: (1) Process Development, and Special Nuclear Materials, and (2) High Level Waste and support for energy programs within DOE and other agencies.

Process Development activities include (1) studies of processes for separation of tritium and helium, and R&D and testing of the performance of components for high-pressure hydrogen service (tritium reservoirs); (2) reactor upgrade and safety programs; (3) new fuel and target design and development; (4) waste heat utilization; (5) improved technologies for the SRP chemical separations areas; and (6) environmental studies.

SRL also has supported Lawrence Livermore National Laboratory in research in plutonium laser isotope separation.

### Nonweapons Activities

The Savannah River Laboratory has developed a number of fields of expertise that are applicable to other DOE programs.

Major areas of emphasis include quality assessment of reactor components, improved reactor safety, confinement of waterborne activity, control of noble gas emissions, second-generation reactor design, and reduction of waste volume from chemical separations facilities.<sup>2</sup>

The experience of SRL extends from the origination of conceptual processes through process development, design support of new production facilities, support of manufacturing operations, environmental transport and impact analyses, and trace element determinations.

<b>BUDGET<sup>3</sup></b> (\$ million):	<b>FY</b>	<b>Total Lab Funding</b>
	1984	86.0
	1985	88.2
	1986	91.5

**ASSETS** Laboratory and Office Space FY 1981: 370,000 square feet.<sup>4</sup> Capital Investment and equipment, \$98 million (FY 1980).

<b>PERSONNEL (FTE):</b>	<b>Total Lab Direct<sup>5</sup></b>	<b>Defense Related (ASDP) Direct</b>
<b>FY</b>		
1975	876	
1976	889	
1977	923	
1978	971	
1979	966	
1980	960 <sup>6</sup>	446(46%)
1981	1042	476(46%)
1982	1167	522(45%)
1983		
1984		
1985		
1986	1000	

1 Savannah River Laboratory Institutional Plan, FY 1981-FY1986, Draft, July 1980, pp. 7-8.  
2 Ibid.  
3 Letter J.T. Lowe to E.L. Morgan, Manager, Savannah River Operations Office, 14 December 1984.

4 Capsule Review of the DOE Research and Development and Field Facilities, U.S. DOE, DOE/ER-0092, September 1980, p. 1A.  
5 Data through 1979 from DOE Staffing Table, January 1981.  
6 FY 1981-FY 1986 Institutional Plan, op. cit., Appendix B.

## Savannah River Production Reactors



Figure 58—Aerial View of L-Reactor

<b>ADDRESS:</b>	See Savannah River Plant
<b>LOCATION:</b>	Five Savannah River production reactors located in 100C, K, L, P, and R site areas at Savannah River Plant (See Figure 52).
<b>ESTABLISHMENT:</b>	Design began 1950; operation initiated late 1953
<b>MISSION:</b>	Production of plutonium and tritium for nuclear weapons and small quantities of other radioisotopes (e.g., Pu-238, U-233, Co-60, Am-241, Cm-242 and Cf-242), primarily for non-military purposes

### History

Initial design of Savannah River Plant reactor sys-

tems began in August 1950, and fabrication of the first reactor by New York Shipbuilding Company began in September 1951. This reactor prototype was used to test the hydraulic and mechanical systems at the vendor's shop and was later modified as the K-Reactor. The five reactors (R, P, L, K, C) were fabricated between September 1951 and May 1954 and were turned over to Savannah River Operations between April 1953 and September 1954. The first reactor placed in operation was R, which started up in December 1953. The last reactor, C, was started up in March 1955.<sup>1</sup> Startup and shutdown dates for each reactor are given in Volume II, Table 3-1.

### Reactor Characteristics

Each reactor is housed in a concrete building containing four major process areas: Assembly Area, Reactor Area, Disassembly Area, and Purification Area (see Figure 58). The Reactor Area, in the central portion of the building, houses the reactor room above ground, the

<sup>1</sup> Extended Service Life of Savannah River Plant Reactors, EPST-60-539, October 1980, p. 7.

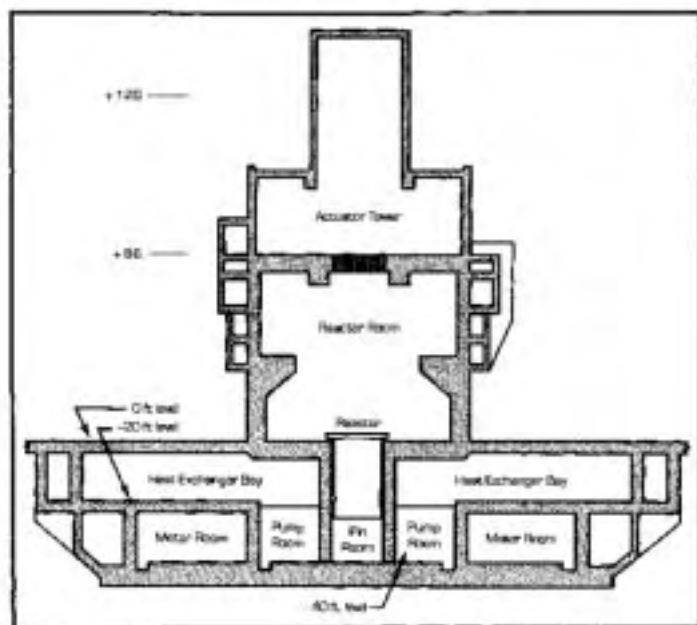

**Figure 59** Schematic Cross-Section of Reactor Process Areas (P, L, K, C Reactors)

reactor tank extending below ground from the floor of the reactor room, the heat exchangers, reactor control rooms, and other facilities (see Figure 59,60). Control system actuators (control and safety rod guide tubes and latches) occupy the reactor room during normal operation, and the actuator room above is occupied by drive systems for the control rods and safety rods. During reloading shut-downs, the fuel charge and discharge machines are moved into the reactor rooms and the actuator system is retracted. The reactor control room is at the +15-foot elevation. The reactor room, pump room and heat exchanger bays are inaccessible during reactor operation. They may be viewed through observation windows and periscopes, and closed circuit television monitors are being tested.<sup>2</sup>

The five reactors are approximately the same size. Each is equipped with an emergency core cooling system but has no secondary containment building. A three-stage activated carbon filter system is employed to remove iodine and particulate radioactivity in the event of a catastrophic accident. However, long-lived noble gases are not contained. Each reactor tank has water-filled top and bottom thermal neutron shields and is surrounded by a 20-inch water-filled thermal shield and a 5-

foot-thick concrete biological shield to protect operating personnel from radiation.

Heavy water ( $D_2O$ ) is utilized as the neutron moderator as well as the recirculated primary coolant.<sup>3</sup> Approximately 250 to 275 MT of  $D_2O$  is required per reactor.<sup>4</sup> Water from the Savannah River or Par Pond (a cooling water impoundment) serves as the secondary coolant.<sup>5</sup> A blanket of helium gas under pressure is maintained over the surface of the heavy water moderator in the reactor tank to increase the saturation temperature of the moderator and inhibit the formation of deuterium gas.

Primary coolant is circulated through each reactor by six parallel pumping systems. The heavy water enters the reactor tank through six inlet nozzles in the water plenum located over the top shield and the foot-thick gas plenum (part of the helium blanket gas system) (see Figure 61). Each fuel and target assembly is suspended from the top of the water plenum.  $D_2O$  enters the fuel assemblies through slots in the plenum tubes and slots and holes in the assembly sleeve housings, and it empties into the moderator before exiting through six outlet nozzles at the bottom of the tank at about 25,000 gallons per minute through each nozzle. The  $D_2O$  then passes through two parallel heat exchangers per closed loop (twelve exchangers per reactor) where heat is transferred to the secondary cooling water before  $D_2O$  recirculation.<sup>6</sup>

The range of operating characteristics experienced at Savannah River reactors is given in Table 8.

#### Reactor Tank and Lattice

The steel reactor vessels made of stainless steel plate are 15 feet high, and 16.25 feet (P,K,L) and 18.5 feet (C) in diameter<sup>7</sup> with a wall thickness of 0.5 inch. The larger diameter of the C-Reactor tank provides space for additional  $D_2O$  moderator to act as a neutron reflector.<sup>8</sup> The reactor cores contain positions for 600 (P,K,L) or 588 (C) principal fuel and target assemblies, a maximum of 4.25 inches in diameter. In addition, there are 162 to 178 secondary positions, one inch in diameter,<sup>9</sup> which are occupied by safety rods, tie bolts connecting the water plenum to the top shield, instrument rods, and special components. The reactor lattice for the P, K, and L is shown in Figure 62.<sup>10</sup> The bottom shield tubes contain monitor pins (600 in P, K, and L; 588 in C) to provide flow and temperature at each fuel position.

Neutron-absorbing control elements (septafolios), each with seven independent motor-driven computer-controlled rods, are in positions (61 in P,K, and L; 73 in C)<sup>11</sup> to control reactivity and the vertical and radial power distribution throughout the reactor. Lithium targets for isotope production are the standard absorber in SRP control rods. Disposable rods containing cad-

2 John P. Church, *Safety Analysis of Savannah River Production Reactor Operations*, DPST SA-100-1, Rev. 983 (Deleted Version) Revised, September 1963, p. 4-1.

3 Heavy water is more effective than graphite in slowing down neutrons and has a smaller absorption cross section. Thus, a heavy water reactor will have a higher neutron multiplication factor, a smaller size, and greater neutron flux than a graphite moderated reactor.

4 E.K. Dukes and R.W. Benjamin, *Savannah River Plant Airborne Emissions and Controls*, DPST-82-1054, Savannah River Laboratory, p. 4-4.

5 The P and K reactors are on a closed loop with the Par Pond. C, K, and L-Reactors discharge hot effluent into streams onsite that go to the Savannah River.

6 Smith, J.A., et al., "Safety Analysis of Savannah River Production Reactor Operation," E.I. DuPont de Nemours & Co. Savannah River Laboratory, DPSTSA-100-1 Rev. 12/78, p. IV-12.

7 *Ibid.*, p. IV-5.

8 DPST SA-100-1, Rev. 12/01, p. 1-5.

9 Church, op. cit., p. 4-4.

10 Smith, op. cit., p. IV-10.

11 *Ibid.*, p. IV-20.



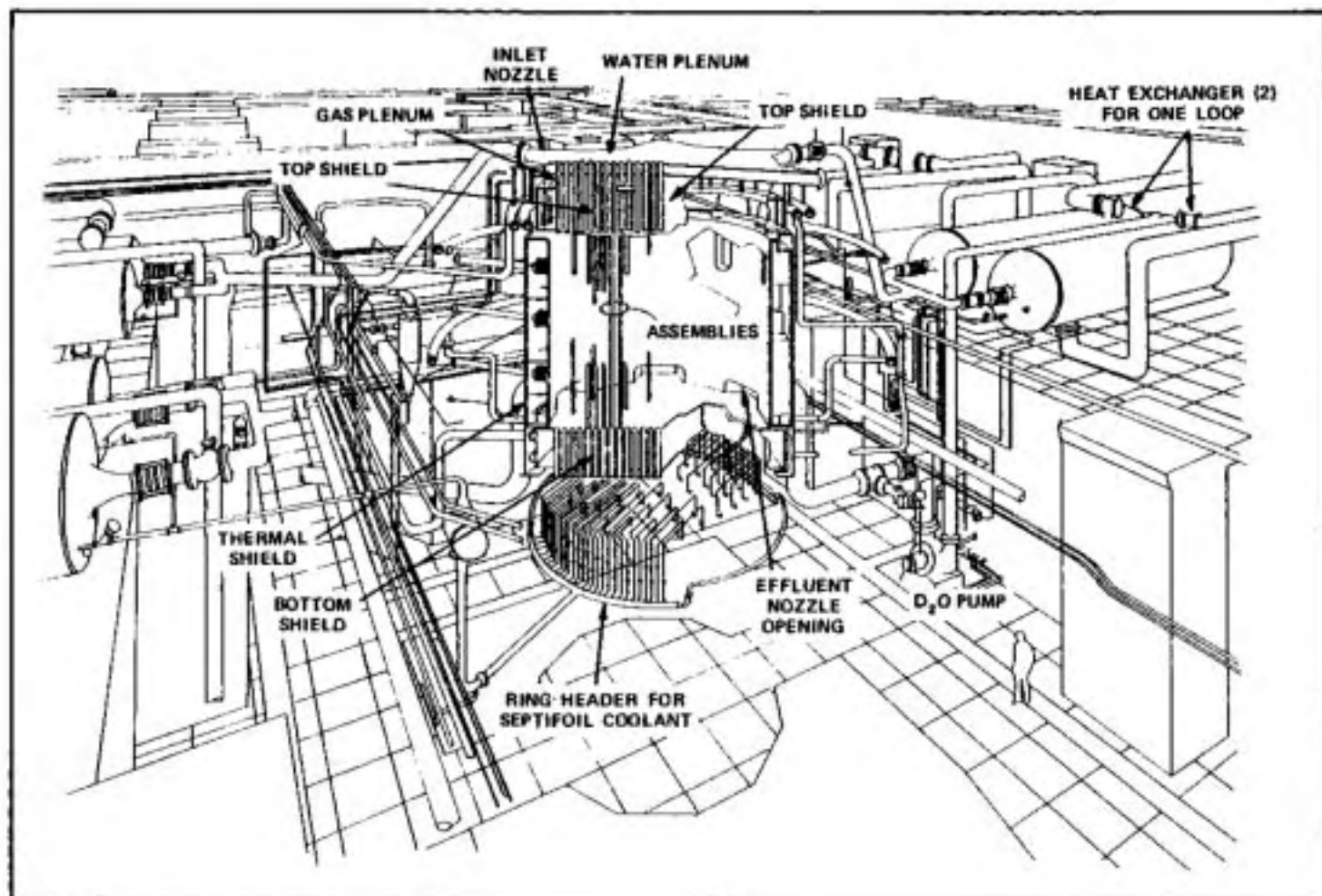

**Figure 60** SRP Reactor Structure

Source: John P. Church, *Safety Analysis of Savannah River Production Reactor Operations*, DPSTSA-100-1, Rev. 5/83 (Deleted Version), Savannah River Laboratory, Revised September 1983, p. 4-2.

mium have also been used to reduce heat generation. Past irradiation campaigns have produced high specific activity cobalt and thulium in control rod positions.<sup>12</sup>

The reactors are equipped with a set of gravity drop safety rods (66 in P, K, and L; 79 in C) normally held above the core by magnetic clutches. The rods are about one inch in diameter and normally cadmium.<sup>13</sup> Safety rods are inserted during normal reactor shutdowns. A backup shutdown system is provided by injection of a solution of gadolinium nitrate (neutron poison) into the reactor moderator.<sup>14</sup>

#### Reactor Operation

Reactor control and process monitoring are carried out in the control room. Reactor power can be adjusted manually from the control console or by online computer. Under manual control, operators can move control rod gangs or individual control rods. Neutron flux, reac-

tor period, reactor power, and axial power are monitored from the console. The D<sub>2</sub>O temperature and flow for each principal fuel and target position are monitored in the control room. The monitor pins in the bottom shield provide information on pressure and temperature in individual assemblies. The process control and safety computer systems, each dual computer systems, provide information to operators on reactor parameters and can initiate reactor shutdown.<sup>15</sup>

#### Assembly Designs<sup>16</sup>

The core of a Savannah River reactor is composed of many individual assemblies each containing fissile material to drive the reactor and/or target materials for breeding. Replaceable core components, called driver assemblies (fuel) or target assemblies, are combined in various loading patterns to form a reactor charge.

12 *Ibid.*, p. V-13.  
13 *Ibid.*, p. IV-35.  
14 *Ibid.*, p. IV-37.

15 Environmental Information Document L Reactor Reactivation, DPST-81-241, Savannah River Laboratory, April 1982, pp. 3-14, 3-17, and 3-24.  
16 *Ibid.*, p. V-1.

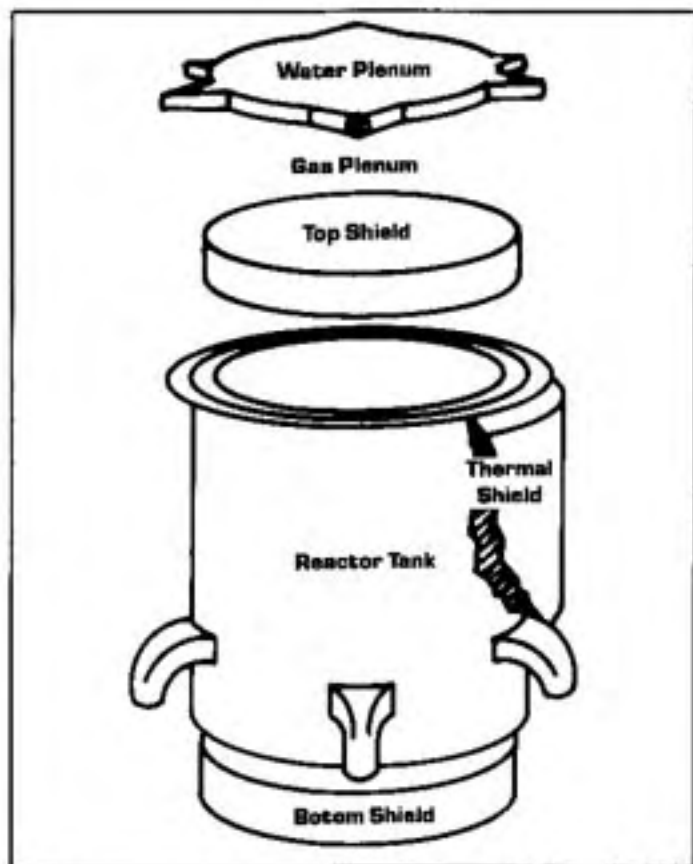

Figure 51 Schematic of reactor tank

Because the core design is frequently altered, new designs are considered to be a part of normal reactor operation.

A driver (or fuel) assembly is generally considered to be one for which insertion increases the charge reactivity and removal decreases the reactivity. A target assembly generally has the opposite effects. Fuel used in a driver can be either uranium (U-235 or U-233) or plutonium. Depleted uranium (U-238) target assemblies are used for weapons-grade plutonium production; enriched lithium targets for tritium. Reactivity is controlled by the ratio of the amount of target to the amount of fuel material. In charges with separate fuel and target assemblies, the amount of target may be reduced by leaving vacant lattice positions.

Some production campaigns require that the function of an assembly switch from target to driver or driver to target during irradiation. In some charge designs, for example, Pu-239 buildup and subsequent fission in the targets is essential to keep the reactor critical. However, the initial assembly is still generally considered to be a

target. An example of the driver to target switch was the Mark 40 plutonium-burning program developed to provide Pu-242 feed material for production of Cm-244 and Cf-252.

#### Fuel Handling and Reactor Loading<sup>17</sup>

Fresh fuel is received and stored in the reactor assembly area where it is placed on racks and hangers in a configuration to prevent criticality. For driver assemblies, a neutron poison is added to the racks (e.g., borated concrete).

The reactor room is equipped with a charge machine, a discharge machine, and an irradiated component conveyor. Charge and discharge machines are used to load and unload fuel and target assemblies. Operations are conducted from the crane room, adjacent to the control room. The conveyor is located in an H<sub>2</sub>O filled canal connecting the reactor room with the irradiated assembly storage basin. The conveyor receives irradiated assemblies from the discharge machine and passes them under the wall of the reactor room. Irradiated assemblies are stored vertically in the water-filled storage basin until the decay heat is low enough to permit shipment.

#### Driver<sup>18</sup> and Target<sup>19</sup> Assemblies

Cross-sectional views of current Savannah River cylindrical fuel (driver) assemblies are shown in Figure 64. The fissile portion can be either coextruded tubes (Mark 16B and Mark 22) or a column of slugs. Drivers containing natural or slightly enriched uranium (e.g., Mark 15) are generally fabricated with slugs.

Target designs are similar to those for driver assemblies and can be either extruded tubes or a column of slugs (see Figure 65). Cross-sections of some typical SRP designs for targets are shown in Figure 66 (see also Table 9). Over forty different types of fuel and target configurations have been used in SRP reactors. Table 10 describes target and fuel assemblies currently at Savannah River, and Table 11 describes other assemblies. Composition and burnup and dimensions of assemblies currently in use are given in Table 12. A chronology showing highlights in the use of fuel and target charges is given in Table 13.

Fuel and target assemblies are enclosed in outer and/or inner aluminum housings that may contain fissile and/or target material, provide discrete coolant channels, and are separately dischargeable. The Mark 16B driver is a combined assembly with an inner lithium target housing for reactivity control. Other combined assemblies alternate one or more fuel tubes or slug columns with one or more target tubes or slug columns (e.g., the Mark 22 assembly).

#### Reactor Charge Design<sup>20</sup>

The type of core used for any production campaign is governed by many factors, including irradiation characteristics, product quality, scheduled demand, target availability, and economics.

<sup>17</sup> DPST-81-241, op. cit., pp. 3-17, 3-22, and 3-23.

<sup>18</sup> *Ibid.*, p. V-5; Church, DPST/SA-100-1, Rev. 9/83, p. 4-14.

<sup>19</sup> Smith, op. cit., p. V-13.

<sup>20</sup> *Ibid.*, pp. V-13, 15.

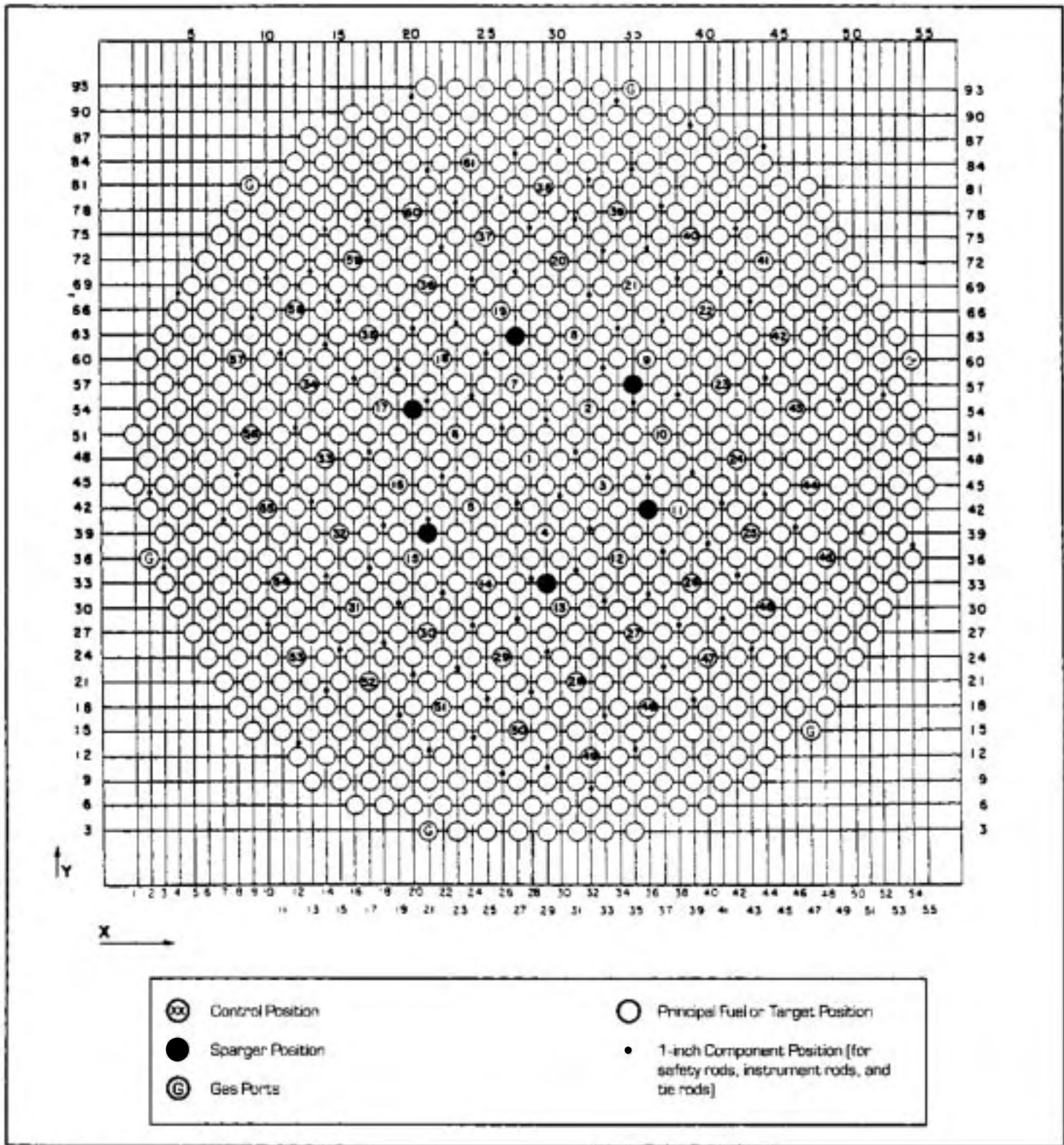
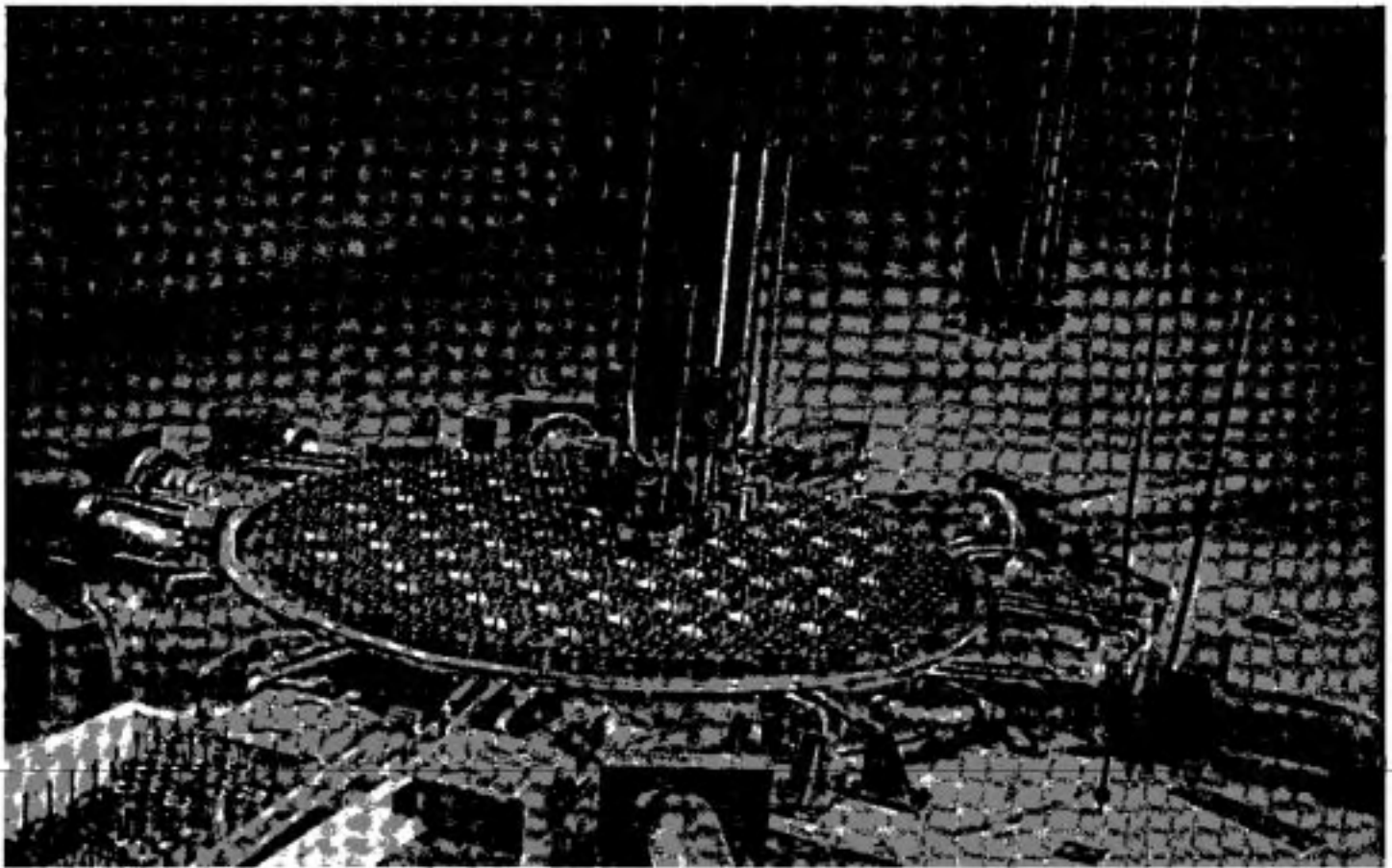

Figure 52 Lattice Arrangement for P, K, and L Reactors

Source: John P. Church, et al., DPSTBA-TOD-1, Rev. 9/83 (Deleted Version), Savannah River Laboratory, Revised September 1983, p. 4-7.





**Figure 63** Fuel Loading Operations at Savannah River Production Reactor

Three basic charge designs are utilized at SRP:

**Uniform Core** - Usually up to 600 assemblies (588 in C) of the same type. Each assembly could contain both fissile and target material, e.g., the Mark 22 charge for tritium production.

**Mixed-Lattice Core** - Contains a large number of driver and target assemblies intermixed in a ratio of 3:3, 4:2, or 5:1 arranged with six assemblies surrounding each control rod position. (If only a small number of target assemblies are present, the charge is considered to be essentially a uniform core.) The Mark 16B-Mark 31 charge for plutonium production is arranged in a 3:3 mixed lattice core.

**Small Core** - Reduced portion of the reactor tank (both radially and axially with height of active core typically about equal to diameter) is used to attain a high neutron flux and high power density. Typically, all D<sub>2</sub>O coolant flow would be directed to 100 to 400 lattice positions, occupied by either an essentially uniform core or a mixed-lattice core. As of 1981, three small core campaigns had been run, two in 1967 and a Californium-252 production campaign in 1969.<sup>21</sup>

Parameters for typical SRP reactor charges are summarized in Table 14.

### Reactor Charges for Plutonium and Tritium

SRP charges are designed to produce tritium, plutonium-239, and other radionuclides. Initial criticality in 1953 (R-Reactor) used a natural uranium charge for production of plutonium (Table 13). Mixed cores containing assemblies with a variety of uranium enrichments have been tried. Since 1968 SR reactors have used only mixed cores of depleted uranium targets<sup>22</sup> and high-burnup, highly enriched drivers in plutonium production campaigns (Mark 14-30, Mark 16-30, Mark 16B-31; see Tables 9 and 11).

Currently, plutonium production in P,K, and L-Reactors is in a mixed 3:3 core of equal numbers of Mark 16B drivers and Mark 31A (or B) targets. A few special target assemblies can be accommodated in either type of charge and vacant positions may be present for reactivity adjustment.<sup>23</sup>

The practice now at Savannah River is to operate the unreflected reactors (P,K,L) with heavy lithium blanketed charges to reduce neutron irradiation of the tank

<sup>21</sup> DPSTSA-100-1, Rev. 12/81, p. 4-35.

<sup>22</sup> E.K. Dukas and R.W. Nejezick, Savannah River Plant Airborne Emissions and Controls, DPST-82-1054, Savannah River Laboratory, p. 5-2.

<sup>23</sup> Church, DPSTSA-100-1, Rev. 0/83, p. 416.



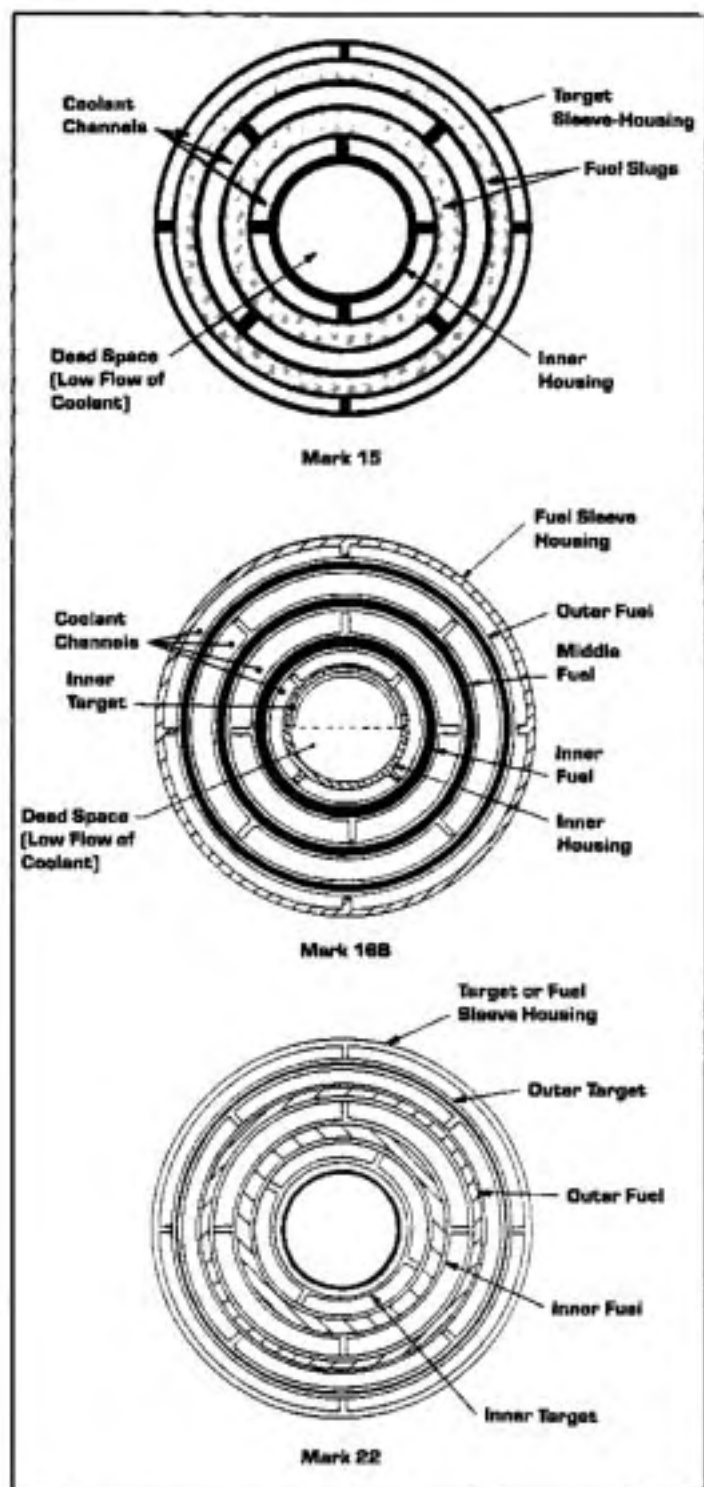

Figure 64 Current Driver Designs

Source: John P. Church, et al., DPSTSA-100-1, Rev. 9/83, p. 4-17.

walls.<sup>24</sup> This slows metallurgical changes in the steel and inhibits production of radioactive Argon-41 in the air-filled reactor annular cavities.<sup>25</sup>

Tritium production (currently, in the C-Reactor) is achieved with Mark 22 fuel assemblies (since 1972, see Table 9) in a uniform core. Some tritium is also produced in lithium control rods, in Mark 60B blanket assemblies, and in the inner lithium-aluminum targets of Mark 16B assemblies during production of plutonium and other isotopes.<sup>26</sup> The Mark 22 charge when used in the P, K, or L-Reactors contains a ring of vacant positions between the Mark 22 core and the outer ring of blanket assemblies to improve the economy of operation.<sup>27</sup>

#### Nuclear Materials Production Cycles

The reactors are designed for batch refueling. Reloading shutdowns are scheduled as required by demands of production programs. They can involve replacement of up to all of the target assemblies and up to all of the driver assemblies, as well as control rods, and a new charge may use outer housings from the previous cycle. Up to several thousand components must be handled and placed in the correct position. Irradiated components are removed by the discharge machine and unirradiated components inserted by the charge machine through the water plenum at the top. The reloading operation may be manual or in automatic sequence controlled by a prepunched tape. To maintain the reactor maximum subcritical, components are replaced in specified order, control rods first, followed by targets and their drivers.<sup>28</sup>

**Mark 16B-31 Charge, Plutonium Production.** Mark 31A depleted uranium targets and lighter Mark 31B targets are staged to obtain maximum burnup of Mark 16B highly enriched drivers. Production of weapon-grade (6 percent Pu-240) plutonium requires target irradiation subcycles of approximately sixty days duration at a nominal power of 2150 Mw<sub>t</sub>. Production of super-grade (3 percent Pu-240) plutonium requires about a thirty-day target irradiation. During current super-grade production operation, five sets of targets are discharged for each fuel cycle; in weapon-grade production three sets are discharged per fuel cycle.<sup>29</sup> Subcycle length depends on the product and the reactor power limit, which varies by reactor and season according to the cooling water temperature and other factors.<sup>30</sup> Currently (since 1983) supergrade plutonium production is in the P, K, and L reactors.<sup>31</sup>

**Mark 22 Charge, Tritium Production.** Mark 22 assemblies combining Li-Al target tubes with U-235-Al fuel tubes are irradiated in a uniform lattice for approximately 200 days per tritium production cycle at a nominal power of 2400 Mw<sub>t</sub>. The irradiation exposure of lithium target elements is limited to prevent dimensional instability, blistering, creep collapse of the cladding, and

24. D.A. Ward, et al., Extended Service Life of Savannah River Plant Reactors, DPST-80-539, Savannah River Laboratory, October 1980, p. 8.

25. Control Technology for Radioactive Emissions to the Atmosphere at U.S. Department of Energy Facilities, PNL-4621, Draft, Pacific Northwest Laboratories, March 1983, p. 19-24.

26. Church, op. cit.

27. DPSTSA-100-1, Rev. 9/83, p. 4-32.

28. Environmental Information Document I, Reactor Activation, DPST-81-241, Savannah River Laboratory, April 1982, p. 3-18.

29. E.K. Dukes and E.W. Benjamin, Savannah River Plant Airborne Emissions and Controls, DPST-82-1054, Savannah River Laboratory, p. 4-3.

30. DPSTSA-100-1, Rev. 9/83, p. 4-11.

31. HAC, FY 1985 EWDA, Part 4, p. 423.



**Figure 65** Depleted Uranium Targets

Metallic uranium cores (black) are clad in aluminum cans to produce targets (silver).

loss of tritium. These effects may occur when the ratio of tritium to lithium atoms is greater than unity.<sup>32</sup> The C Reactor (since the early 1980s) is dedicated to tritium production with the Mark 22 charge.<sup>33</sup>

**Mark 22S-25 Charge, Mark 15 Charge, Plutonium Production.** The Mark 15 program was terminated by DOE in FY 1984 after funding was withheld by Congress due to enrichment costs.<sup>34</sup> Operation with a uniform lattice slightly enriched (1.1 percent U-235) Mark 15 core would have produced "at least 25 percent" more plutonium than the Mark 16B-31 mixed lattice.<sup>35</sup> (Similar, although less efficient, uniform lattices have been used in earlier SRP reactor operation<sup>36</sup> prior to 1968.<sup>37</sup>) The Mark 15 charge is the heaviest designed to date, weighing 107 tons (P,K,L-Reactors) or 125 tons (C-Reactors).<sup>38</sup>

Operation with Mark 15 cores was to start in August 1986, and full conversion of three reactors (P,K,L) was planned by late FY 1987.<sup>39</sup> A full charge demonstration

in the K-Reactors, to verify design and operability, occurred in August and September of 1983.<sup>40</sup>

To replace the Mark 15, DOE is pursuing a fallback option, the Mark 22S-25 core. This core is built of highly enriched drivers (Mark 22S) and natural uranium targets (Mark 25). The Mark 22S-25 core will give about half the plutonium productivity increase of the Mark 15 (10 to 12 percent) over the current Mark 16-31 core. A test charge will be fabricated in FY 1986 and irradiated in FY 1987.<sup>41</sup>

#### Reactivity Variation in Charges

Reactivity variation with exposure for SRP fuel charges is shown in Figure 67. The reactivity (percent by which the multiplication factor  $k$  differs from criticality,  $k = 1$ ) is regulated by neutron absorbing control rods. For the Mark 16B-31 charge the variation (shown for sixty-day weapon-grade plutonium production subcycles) illustrates that the reactivity can increase during a sub-cycle as a fissionable isotope (Pu-239) is formed. An increase also occurs when the target depletes faster than the fuel. The irradiation cycle for the Mark 15 charge is shown to be thirty days, corresponding to the production of supergrade (3 percent Pu-240) plutonium.<sup>42</sup>

32 Church, DPSTSA-100-1, Rev. 9/83, p. 4-47.

33 HAC, FY 1985 EWDA, Part 4, p. 423.

34 HAC, FY 1986 EWDA, Part 4, p. 382.

35 Major Accomplishments at the Savannah River Plant Since January 1981, DOE, p. 1.

36 Draft EIS, op. cit.

37 DOE Savannah River Operations Office, Memorandum-to-File, 05000, 4 April 1989.

38 Church, DPSTSA-100-1, Rev. 9/83, p. 4-11.

39 SIAC, FY 1985 EWDA, Part 4, p. 427.

40 Draft EIS, op. cit., DOE Savannah River Operations Office, Memorandum-to-File, 05000, 4 April 1983.

41 HAC, FY 1986 EWDA, Part 4, pp. 382, 384.

42 Church, DPSTSA-100-1 Rev. 9/83, p. 4-24.

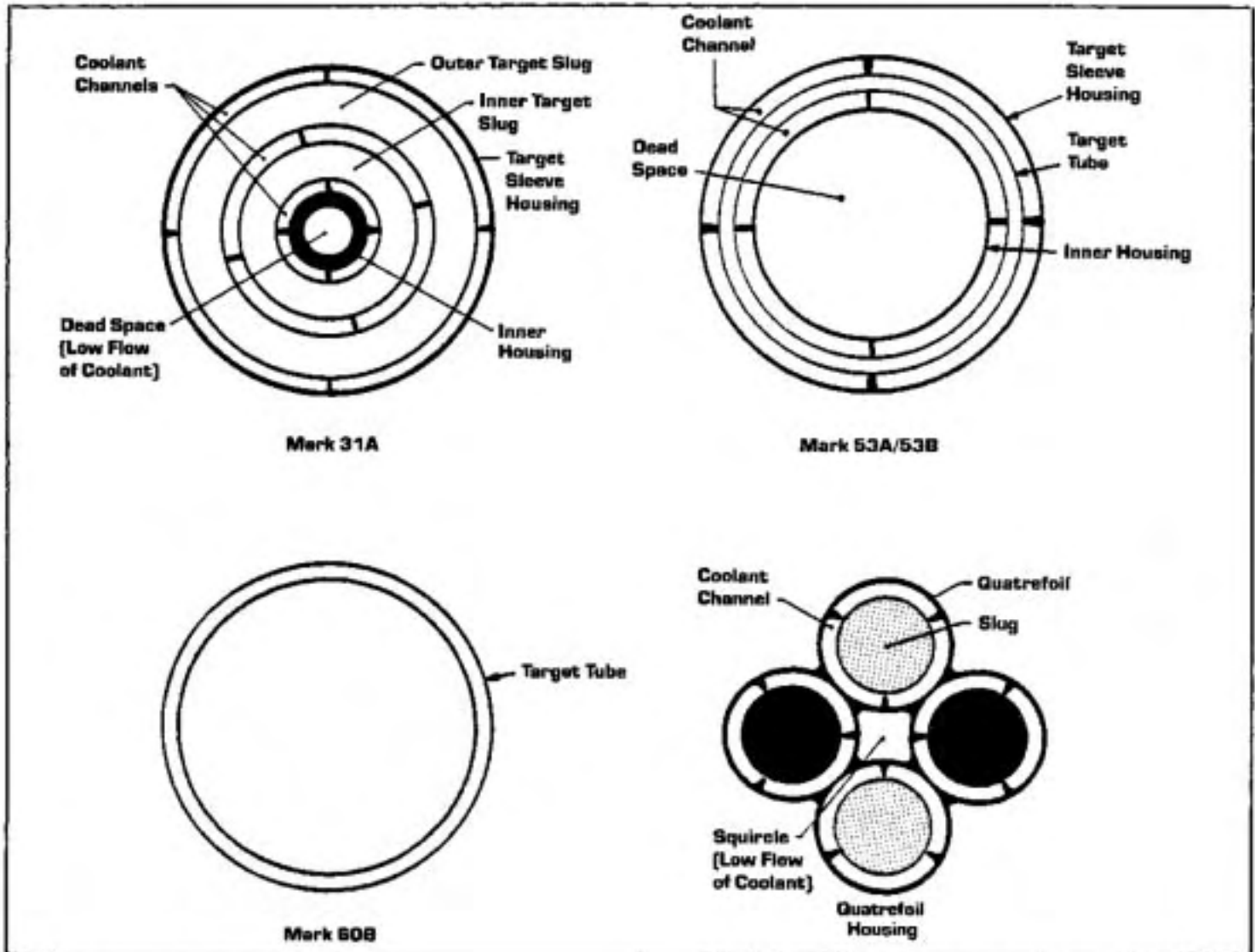

Figure 66 Current Target Designs

Source: John P. Church, et al., DPSTSA-100-1, Rev. 5/83, p. 4-18.

Table B  
**Range of Operating Characteristics Experienced by Savannah River Reactors (R,P,L,K,C)**

Thermal Neutron Flux (full power):	$5 \times 10^{13}$ to $7 \times 10^{15}$ n/cm <sup>2</sup> -sec
Reactor Power (full power):	650 to 2915 MW
Assembly Power:	up to 21 MW
Prompt Coefficient:	$+2 \times 10^{-5}$ to $-15 \times 10^{-5}$ k/°C <sup>a</sup>
Moderator Coefficient:	$-1 \times 10^{-5}$ to $-35 \times 10^{-5}$ k/°C
Reactivity in Control Rods:	Up to 30% k at cycle beginning to 0.5% k at cycle end
Reactivity in Xenon After Shutdown:	Up to 60% k
Irradiation Cycle Length:	4 to 400 days
Fuel Heat Flux:	Up to 2,900,000 Btu/hr-ft <sup>2</sup>
Total D <sub>2</sub> O Flow Rate:	90,000 to 183,500 gpm <sup>b</sup>
D <sub>2</sub> O Flow per Assembly:	Up to 1050 gpm
Assembly Coolant Velocity:	Up to 72 ft/sec
U-235 Loading:	Up to 1650 kg per charge; up to 4 kg per assembly

- a Overall temperature coefficient (prompt plus moderator) is always negative.  
 b Gallons per minute.

Source: Smith, J.A., et al., "Safety Analysis of Savannah River Production Reactor Operation," E.I. duPont de Nemours & Co. Savannah River Laboratory, DPSTSA-100-1 Rev. 12/76, p. V-26. This table includes variables associated with production programs only. The large number of experimental fuel and target assemblies are not included.

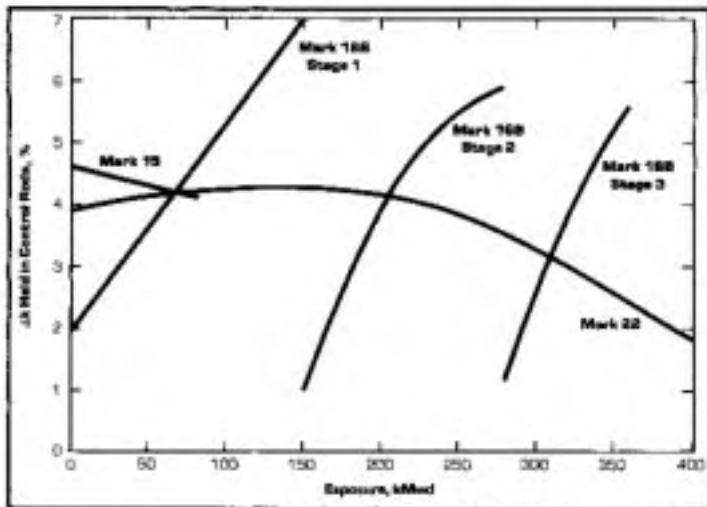

**Figure 67** Typical Reactivity Variation with Exposure

Source: Church, DPSTSA-100-1, Rev. 5/83, p. 4-25.



Table 9  
**Current Savannah River Fuel and Target Assemblies**

Mark 15	Two concentric columns of short tubular fuel slugs of slightly enriched uranium (1.1 weight percent U-235) with an inner aluminum housing. Fuel is separately dischargeable from an aluminum universal sleeve housing.
Mark 16B	Three concentric fuel tubes (12.5 foot core) of U-235-Al alloy (3380 grams for blanketed charges, 3200 grams for reflected charges) in an aluminum universal sleeve-housing. A separately dischargeable Li-Al target is contained inside the inner fuel tube. Same as Mark 15 except for higher U-235 content and a slightly different distribution of fuel among tubes.
Mark 22	Two concentric fuel tubes (12.5 foot core) of U-235-Al alloy (3200 grams U-235) resting on a separately dischargeable bottom fitting in an aluminum universal sleeve-housing. Contains two Li-Al target tubes external and internal to the fuel. The inner target is separately dischargeable.
Mark 31A	Two concentric columns of short tubular target slugs of depleted uranium (0.20 weight percent U-235) in an aluminum universal sleeve-housing.
Mark 31B	Single column of depleted uranium slugs, identical to outer slugs used in the Mark 31A.
Mark 42	Same mechanical design as Mark 16B except fuel tubes contain PuO <sub>2</sub> -Al instead of U-Al. Targets for high Pu-242 production.
Mark 53A, 53B	Single column consisting of coextruded NpO <sub>2</sub> aluminum inner housing that are dischargeable as a unit from a universal sleeve housing. Targets to produce Pu-238.
Mark 60B	Convection-cooled Li-Al alloy coextrusion with Al cladding (12.5 foot core). Used as blanket assembly to reduce thermal shield heat load, to reduce neutron damage to the reactor tank wall, to make tritium, and to restrict the formation of Ar-41 outside the reactor.
Mark 62	Li-Al target tube that is separately dischargeable from an aluminum universal sleeve-housing. Used to produce tritium.

Source: Church, DPSTSA-100-1, Rev. 9/63, p. 4-15. Smith, DPSTSA-100-1, Rev. 12/76, p. V-5.

Table 10  
**Dimensions of Targets**

Dimensions (Inches) <sup>a</sup>		Mark 31A	Mark 31B
Outer Housing	OD	4.110	4.110
	ID	4.010	4.010
Outer Target	OD	3.700	3.700
	ID	2.590	2.590
Inner Target	OD	2.200	-
	ID	1.250	-
Inner Housing	OD	1.000	2.250
	ID	0.800	2.130
Cladding Thickness		0.030	0.030

a. OD = outer diameter, ID = inner diameter.

Source: DPST-70-463, Savannah River Laboratory, 1970, p. A-29.

Table 11  
**Other Savannah River Fuel and Target Assemblies**

Mark V-B*	Two concentric columns of fuel slugs of natural uranium (aluminum outer housing; no inner housing).
Mark V-E*	Two concentric columns of fuel slugs of slightly enriched (0.9 weight percent) uranium (aluminum outer and inner housing tubes).
Mark V-R*	Two concentric columns of short tubular fuel slugs of slightly enriched uranium (0.66 weight percent U-235) with aluminum semipermanent outer housing and separately dischargeable fuel and inner housing.
Mark VI*	Tubular fuel element of U-235-Al alloy, with an internal column of solid Li-Al target slugs.
Mark VI-B*	Two concentric tubular fuel elements of U-235-Al alloy with two Li-Al target tubes, one internal and one external.
Mark VI-E*	Two concentric fuel tubes of U-235-Al alloy with three Li-Al target tubes, two internal and one external. The innermost target tube is separately dischargeable.
Mark VI-J*	Tubular fuel element of U-235-Al alloy with an internal column of hollow-core Li-Al target slugs.
Mark VII*	Quatrefoil loaded with hollow slugs of natural uranium.
Mark VII-A*	Similar to Mark VII except that the hollow slugs and quatrefoil are larger to permit operation at higher coolant flows.
Mark XII*	Three concentric fuel tubes (10-foot core) of U-235-Al alloy and an aluminum inner housing that are separately dischargeable from an aluminum semipermanent sleeve housing (driver for Curium-II charges).
Mark XII-A*	Three concentric fuel tubes (12.5-foot core) of U-235-Al alloy. This assembly is similar to Mark XII except for its core length and higher enrichment (driver for U-235 program, with Mark 50A and 50B).
Mark 14 **	Three concentric fuel tubes (12.5 foot core) of U-235-Al Alloy (1600 grams U-235) and an inner housing that are separately dischargeable from an aluminum universal sleeve housing. Mixed-lattice charge in four subcycles, with progressively lighter targets (Mark 30A, B, C, D) produces Pu-239, U-236, and tritium.
Mark 16 **	Three concentric fuel tubes (12.5 foot core) of U-235-Al alloy (about 3000 grams U-235) resting on a separately dischargeable bottom fitting in an aluminum universal sleeve housing. A separately dischargeable Li-Al target is contained inside the inner fuel tube. Mixed-lattice core with up to six cycles using Mark 30 targets produces Pu-239, U-236, and tritium.
Mark 16A **	Same as Mark 16 except the outer and middle fuel tubes have thinner claddings and thicker cores. Used as a heavyweight driver in enriched-depleted programs.
Mark 18 *	Three concentric fuel tubes with 6-foot-long cores of U-235-Al alloy and an aluminum inner housing that are dischargeable as a unit from an aluminum semipermanent sleeve housing. Used as driver for Californium-I program.
Mark 18A *	Three concentric fuel tubes of U-235-Al alloy and an aluminum inner housing that are dischargeable as a unit from a semipermanent sleeve housing that contains a Pu-242 target. Used as driver for Californium-I program; the Pu target is to produce transplutonium isotopes. Target housings may be irradiated separately.
Mark 30A **	Two concentric columns of short tubular target slugs of depleted uranium (0.14 weight percent U-235) with aluminum universal sleeve housing and separately dischargeable targets and inner housing.
Mark 30B,30C,30D **	Single column of short tubular target slugs of depleted uranium (0.14 weight percent U-235) with aluminum universal sleeve-housing and separately dischargeable targets and inner housing. Used with Mark 14 or Mark 16 drivers. Currently used Mark 31A,B are the same as Mark 30 except for 0.20 weight percent U-235.

Table 11 (cont.)  
**Other Savannah River Fuel and Target Assemblies**

Mark 40 *	Three concentric fuel tubes with 12.5-foot-long cores of Pu-Al alloy in an aluminum universal sleeve housing with a disposable inner housing. A separately dischargeable target can be used instead of the inner housing. Used to produce Pu-242 feed material for the Cf-252 program.
Mark 41	Two coextrusion-clad coaxial target tubes. The 10-foot core of the outer tube contains PuO <sub>2</sub> -Al to produce Pu-242 of approximately 98 isotope percent. The outer tube and an aluminum basket are retained in a universal sleeve-housing with a retaining ring. The inner tube with a 12-foot core of Li-Al alloy is separately discharged from the basket and replaced with an inner tube having a different Li-6 content to maintain specified reactivity.
Mark 50A *	A column of 15.2-inch-long tubular target slugs of compacted thorium and an aluminum inner housing that are dischargeable as a unit from an aluminum semi-permanent outer housing. Used for production of U-233.
Mark 50B *	A column of 9.5-inch-long tubular target slugs of compacted thorium and an aluminum inner housing that are dischargeable as a unit from an aluminum semipermanent outer housing.
Mark 51	Quatrefoil containing up to four columns of 6-inch-long slugs, each of which contains a blend of Cm-Am oxide and aluminum. Used to produce Cf-252 in Californium-1 program. Small core in short cycle uses six Mark 51 targets and ninety Mark 18 drivers.
Mark 52 •	Single column of elements consisting in part of two or three NpO <sub>2</sub> and aluminum coextruded tubes. Either Li-Al targets or aluminum spacers are used above and below the NpO <sub>2</sub> tubes. Used to produce Pu-238.
Mark 53,53A,53B	Single column consisting of coextruded NpO <sub>2</sub> - aluminum tube(s) with aluminum spacers and an aluminum inner housing that are dischargeable as a unit from a universal sleeve housing. Used to produce Pu-238. Mark 51 **A sleeve housing, the bottom half of which contains an 8-foot-long aluminum clad coextrusion of NpO <sub>2</sub> and aluminum. The cladding, the coextrusion, and a bottom fitting are welded into the sleeve housing to form a single unit. Used to produce high-purity Pu-238 (less than 0.3 ppm Pu-236) by irradiation in the reflector region of the Californium-1 charge.

\* These assemblies are now obsolete but represent design variations utilized or proposed in the past.

\*\* Assembly designs compatible with current operation but not in use.

Source: Smith, J.A., et al., "Safety Analysis of Savannah River Production Reactor Operation," E. I. DuPont de Nemours & Co. Savannah River Laboratory, DPSTSA-100-1 Rev. 12/76, pp. V-5.6.

Table 12  
**Fuel Composition and Burnup for Current Assemblies**

Per Assembly	Mark 16B	Mark 22	Mark 31A	Mark 31B
U-235 (kg)	3.360	3.200	0.671	0.456
U-238 (kg)	0.767	0.600	332.850	225.950
U-234 (kg)	0.087	0.100	-	-
U-236 (kg)	1.690	0.394	-	-
Power (Mw)	6.0	5.1	2.0-3.1 <sup>a</sup>	2.0-3.1 <sup>a</sup>
Fission Exposure (MwD) (approx.)	1188.0	1005.0	126.0	106.0
Days Irradiated	198	197	55	44
Days Cooled	180	180	180	180

a. The power increases in Mark 31 assemblies during a subcycle.

Source: D.H. Stockard and C.T. Randall, Safety Analysis—200 Area, Savannah River Plant Separations Area Operations, DPSTSA-200-10, Savannah River Laboratory, August 1980, p. V-12.

Table 13  
**Chronology: Fuel and Target Charges Used at SRP  
(excluding test irradiations)**

1953	Initial criticality of first SRP reactor, solid material uranium slugs in quaterfoil to produce Pu-239 (Mark I).
1955	Mixed Lattice U-233-Pu-239 producer charge, four assemblies containing a mixture of thorium and U-235-Al slugs, and two assemblies containing natural uranium slugs in each cluster.
1955	First cobalt irradiations, over 30 megacuries of Co-60 subsequently produced.
1956	Hollow natural uranium slugs (Mark V) with forty-two U-235 fuel assemblies to produce Pu-239. Subsequently modified to Mark VI-A.
1956	Tritium producer charge, fuel assemblies containing a mixture of U-235-Al and Li-Al solid slugs, Li-Al blanket.
1957	Tritium producer charge, each lattice position containing Li-Al slugs inside a U-235-Al fuel tube (Mark VI). Subsequently modified to Mark VI-J.
1957	Mixed-lattice U-233-Pu-239 producer charges. Hollow natural uranium slugs, thorium targets, and U-235-Al fuels.
1958	Charge containing 444 natural uranium fuel assemblies, 114 tubular U-235-Al fuels and forty-two depleted uranium assemblies (0.14 percent U-235) for production of Pu-240.
1958	Irradiation of $\text{NpO}_2\text{-}^{237}$ for Pu-238 production started. Subsequent charges contained as many as fifty-four $\text{NpO}_2\text{-}^{237}$ assemblies in plutonium, tritium, and U-233-producer charges.
1959	Pu-239-Al fuel irradiated for production of transplutonium elements. Subsequent charges contained as many as 106 Pu-239-Al assemblies in both plutonium and tritium producer charges.
1962	Tritium producer charge, concentric U-235-Al and Li-Al tubes, two of each per assembly (Mark VI-B).
1962	Concentric natural uranium slugs for Pu-238 production, tubular U-235-Al fuels (Mark V-B).
1962	Mixed-lattice H-3/U-233 production, five tritium producers, and one thorium assembly per cluster, thorium blanket.
1963	Concentric slightly enriched uranium metal (0.95 percent U-235) slugs and Li-Al blanket for H3/Pu-239 production (Mark V-E). Subsequently modified to Mark V-R (0.86 percent U-235).
1964	Mixed lattice containing three Pu-239-Al and three U-235-Al assemblies per cluster. Curium-I campaign.
1965	High flux ( $6 \times 10^{15}$ n/cm <sup>2</sup> sec) operation.
1965	Mixed lattice H-3-U-233 production, four U235-Al fuels with Li-Al targets, and two ThO2 target assemblies in each control cluster, LiAl blanket.
1965	Semipermanent housings used for Mark V-E.
1965	Mixed lattice containing 175 U-235-Al fuels, thirty-seven Pu-240-242 targets, and sixty-six bismuth blanket assemblies for Cm-244 and Po-210 production. Curium II campaign.
1966	Charge containing 258 natural uranium assemblies, 294 slightly enriched uranium metal assemblies, and forty-eight U-235-Al fuels.
1966	Fuel-target assemblies containing two concentric U-235 fuel tubes and three Li-Al targets. The inner target is separately dischargeable (Mark VI-E).
1966	Fuel assemblies containing three concentric U235-Al fuel tubes used as fuels in the mixed-lattice production of Cm-244 (Mark XII).



Table 13 (cont.)  
**Chronology: Fuel and Target Charges Used at SRP**

1967	Mixed lattice U-233 production; three fuels containing three concentric U-235-Al fuel tubes (Mark XII-A), and three ThO <sub>2</sub> target assemblies. Depleted uranium metal blanket.
1968	Universal sleeve housings used for Mark 14.
1968	Mixed lattice Pu-239 production and high burnup of alloy fuel; fuels containing three concentric U-235-Al fuel tubes (Mark 14), and depleted uranium metal target assemblies (Mark 30). Targets were staged to increase fuel burnup. <sup>a</sup>
1968	Mixed lattice Pu-242 production initiated; three concentric Pu-239-240-Al tubes (Mark 40).
1969	Mixed lattice Pu-239 production and U-235 concentration; fuels containing three concentric heavy U-235-Al fuel tubes (Mark 16) and depleted uranium metal target assemblies (Mark 30). Subsequently modified to Mark 16B and Mark 31.
1969	High flux ( $7 \times 10^{15}$ n/cm <sup>2</sup> sec) Cf-252 production (Californium-I campaign); three concentric U-235-Al fuel tubes six feet long with Pu, Cm, and Am target material. First use of universal sleeve-housing with integral target material (Pu-242). Fuel with Al housing (Mark 18); fuel with target housing (Mark 18A).
1970	Pu-239 production with low Pu-238 (less than 0.3 ppm).
1972	Tritium producer charge, concentric U-235-Al and Li-Al tubes (two of each per assembly). Compatible with universal sleeve housing (Mark 22).
1975	Mark 16-31 mixed lattice with 24 Mark 41 PuO <sub>2</sub> -Al assemblies in Mark 31 target positions for concentrating Pu-242.
1979	Mark 16B-31 mixed lattice with special target slugs replacing Mark 16B Li-Al inner targets in six Mark 16B assemblies for production of special isotopes.
1980	Mark 16B-31 mixed lattice with 56 Pu-239-240-Al Mark 42 assemblies for producing high assay Pu-242 plutonium.
1985	3 percent Pu-240 production with Mark 16B-31 charge; tritium production with Mark 22 charge (C-Reactor); Pu-242 production in Mark 42 assemblies; Pu-238 production in Mark 53. <sup>b</sup>
1986	Operation with Pu-239 producer charge, Mark 15 assemblies of concentric slightly enriched uranium metal (1.1 percent U-235) slugs. Super-grade production in one reactor (late FY 1986). Compatible with universal sleeve housing. <sup>c</sup>
1987	Test irradiation of Mark 22S-25 mixed lattice for increased efficiency of 3 percent Pu-240 plutonium production. <sup>d</sup>
Future	Mixed lattice charges with U <sub>3</sub> O <sub>8</sub> -Al fuel assemblies drivers fabricated with powder metallurgy techniques.

<sup>a</sup> The change from natural uranium fuel to high burnup highly enriched drivers in plutonium production was for the purpose of increasing the production of U-235 and Pu-239. The Pu-237 was required for the production of Pu-238. AEC, Report to Congress, January 1969, p. 39.

<sup>b</sup> Projected HAC, FY 1985 EWDA, Part 4, p. 427.

<sup>c</sup> *Ibid.*, p. 425.

<sup>d</sup> HAC, FY 1986 EWDA, Part 4, p. 384.

Source: Church, DPSTSA-100-1, Rev. 12/91, pp. 4-39-41.

Table 14  
**Nominal Operating Parameters for Typical SRP Charges**

	<u>Uniform/T</u>	<u>Mixed-Lattice</u>	<u>Uniform/Pu-239</u>	<u>Small Core/High Flux</u>
Principal Fuel	Mark 22	Mark 16B	Mark 15 <sup>a</sup>	3 tube - enriched U <sup>b</sup>
Principal Target	Lithium Housings	Mark 31	-	Transuranic isotopes
Power, Mw Per Driver	6.0	7.4	4.7	8-21
Per Target	-	2.5-4.8	-	1.5
Total Reactor	2400	2150-2340 <sup>c</sup>	2410	735-1550
Uranium-235 Loading per fuel assembly, kg	3.2	3.2-3.36	-	0.17
Total charge loading, kg	1400	933-980	-	16.4
Enrichment, %	75	60	1.1	93
Burnup, %	40-50	35-50	8	40
Final Exposure, MwD	400,000- 500,000	300,000-400,000	75,000	5000
Thermal Neutron Flux, n/cm <sup>2</sup> sec)	1 x 10 <sup>14</sup>	2 x 10 <sup>14</sup>	1 x 10 <sup>14</sup>	7 x 10 <sup>15</sup>

<sup>a</sup> The Mark 15 program was cancelled in 1984.

<sup>b</sup> Mark 16A drivers and Mark 31 targets (now obsolete) have been used. DPSTSA-100-1, Rev. 75, p. V-26.

<sup>c</sup> 2150 Mw: Smith, DPSTSA-100-1, Rev. 12/76, p. V-26. 2150 Mw: DPSTSA-100-1, Rev. 12/81, p. 4-44. 2350 Mw: Church, DPSTSA-100-1, Rev. 9/83, p. 4-25. 2350 Mw is typical L-Reactor operating power with Mark 16B-31 charge. Draft Environmental Impact Statement, L-Reactor Operation, Savannah River Plant, DOE/EIS-01080, Vol. 1, September 1983, p. 2-14.

Source: Church, DPSTSA-100-1, Rev. 9/83, pp. 4-23, 25.

## Savannah River Fuel and Target Fabrication Facilities

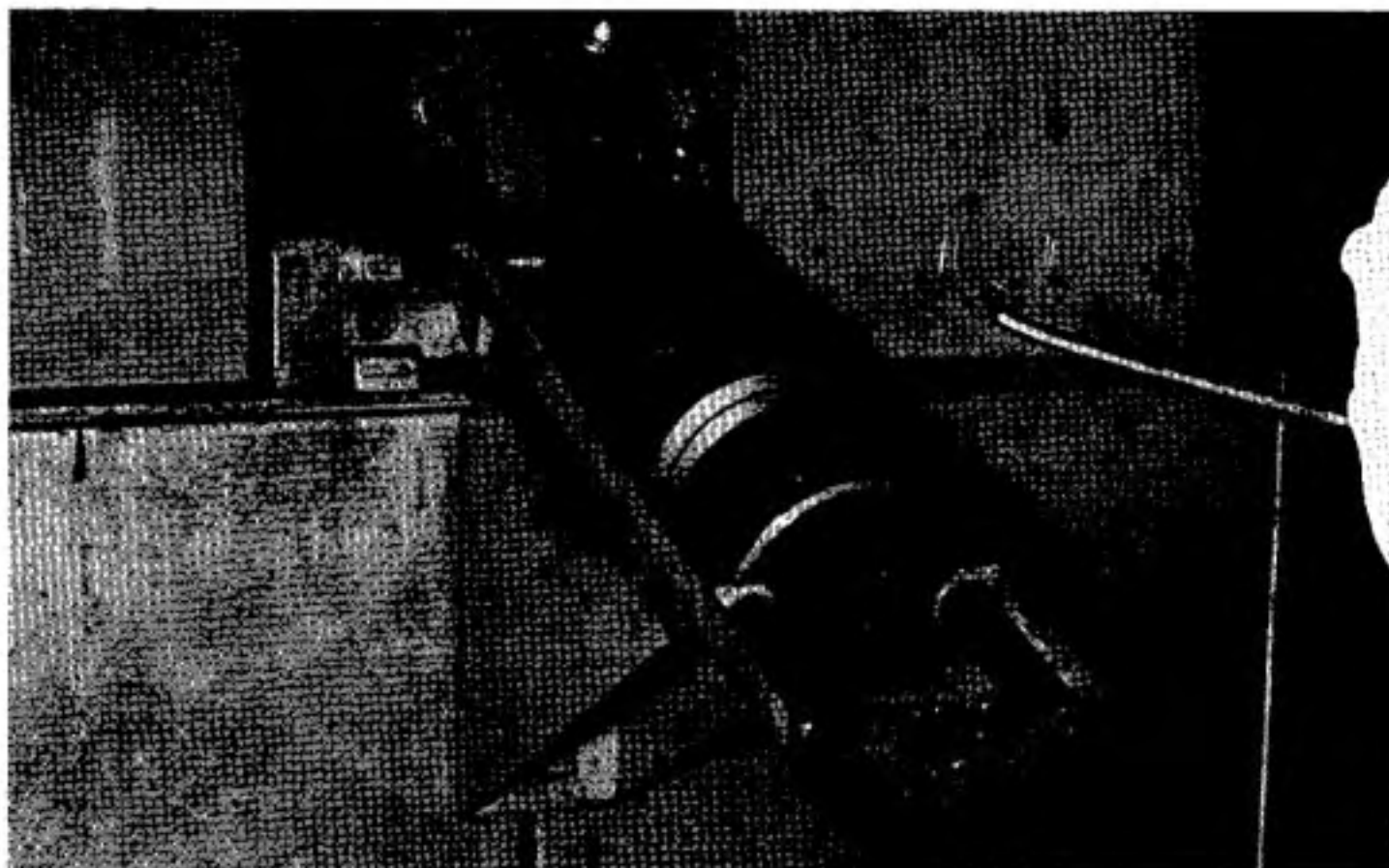

**Figure 68** Preheated Billet Immediately Prior to Extrusion

**ADDRESS:** See Savannah River Plant

**LOCATION:** 300-M area at Savannah River Plant

**MISSION:** Fabrication of driver fuel and target elements to be irradiated in SRP production reactors. Major products are extruded fuel tubes of enriched uranium-aluminum alloy, extruded target tubes of lithium-aluminum alloy (for tritium production), and aluminum canned targets of depleted uranium metal (for plutonium production).

**ESTABLISHMENT:** Fuel fabrication operations at M-area begun 1952.<sup>1</sup>

**FACILITIES:**

- Alloy Extrusion Plant (321-M)
- Uranium Metal Fabrication Plant (313-M)
- Target Extrusion Plant (320-M)
- Metallurgical Laboratory (322-M)
- Fuel Production Facility (to be completed in 1988)

### Process Descriptions<sup>2</sup>

At the Fabrication Facilities materials including lithium, depleted uranium, enriched uranium, and aluminum go through various metal working operations such as casting, machining, plating, extrusion, and welding. Depleted and slightly enriched uranium target cores are received from the Feed Materials Production Center (FMPC) at Fernald, Ohio, for treatment and canning at the 313-M building. Highly enriched uranium for driver fuel is received—from the Y-12 Plant at Oak Ridge—at the 321-M building, where it is alloyed with aluminum. The HEU-Al billets are extruded into fuel tubes for use

<sup>1</sup> Environmental Radiation Surveillance Report, July 1962-June 1963, Georgia Department of Natural Resources, Environmental Protection Division, p. 57.

<sup>2</sup> ESDA, Savannah River Operations Office, "Integrated Radioactive Waste Management Plan, Savannah River Plant, Aiken, South Carolina," SRO-TWM-76-1, June 1976, pp. V-1 to V-8; Dukes and Benjamin, DPST-82-1054, op. cit., p. 5-2.

## Savannah River Fuel and Target Fabrication Facilities

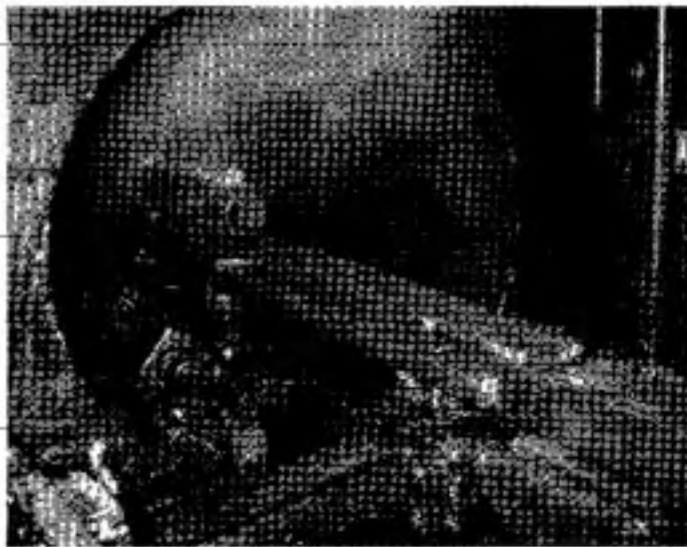

Figure 69 Enriched Fuel Tube Leaving the Press



Figure 70 Uranium Fuel Cleaning Process

with targets of lithium or depleted uranium. Also, enriched lithium is received from the Y-12 Plant at the 320-M building, where it is alloyed with aluminum and extruded into Li-Al target tubes for tritium production.

Tubular fuel and target elements are manufactured in the 321-M building by coextrusion of a composite billet. In this process, the tube is formed and the core is simultaneously clad with aluminum. Cores consist of fuel or target material dispersed in an aluminum matrix. Most elements manufactured in the 321-M building contain enriched uranium cores, but some contain plutonium and neptunium cores that are fabricated in the separations areas. After extrusion, tubes are chemically cleaned to remove graphite and lead-oil lubricant. They are successively treated with hot perchloroethylene, caustic solution (sodium hydroxide), and nitric acid; intermediate and final water rinses are also used.

In the 313-M building, target and fuel elements for SRP reactors with natural (0.7 percent U-235), depleted (0.14-0.20 percent U-235), or slightly enriched (up to 1.1 percent U-235) uranium are bonded in aluminum cans by several techniques. Since 1968, only depleted uranium cores have been used in conjunction with high enriched drivers, with the exception of some experimental cores containing 1.1 percent U-235 processed in 1972.

The depleted uranium cores, after receipt from the Feed Materials Processing Center (FMPC), are cleaned at SRP with boiling perchloroethylene and hot nitric acid, anodically etched, and then electroplated to form a 0.3-mil-thick nickel layer. The nickel assures a good bond with the aluminum can and protects the uranium from oxidation during heating. The nickel-plated core is

loaded into an aluminum can, capped, preheated to 540 C, and pressed through a die to size the can onto the core. The canned elements are then cleaned, welded, inspected, and tested.

Starting in 1988, SRP drivers are to be fabricated from uranium oxide ( $U_3O_8$ )-aluminum alloy instead of U-Al metal alloy. A new powder metallurgy (PM) process is to replace the melting, casting, and machining processes previously used to form fuel billets. PM will reduce fuel manufacturing costs and increase reactor productivity. In addition, conversion operations for recycle uranium are to be transferred from Y-12 to SRP, where or alloy from Y-12, recycle uranium oxide from ICPP, and recycle uranium nitrate are to be converted to  $U_3O_8$ .<sup>3</sup>

### Production Activities

Over one-quarter-million slugs, housings, control rods, fuel tubes, and target tubes are produced annually by about 300 employees.<sup>4</sup>

Fuel and target assemblies fabricated to support plutonium and tritium production:

FY	Production (MT)
1983	2000 <sup>5</sup>
1984	3200 <sup>6</sup>

Activities in FY 1983 and FY 1984 included fabrication of Mark 16B driver assemblies and Mark 31A target assemblies for super-grade plutonium production, and fabrication of Mark 22 assemblies for tritium production. A Mark 22-25S test change was fabricated in FY 1986.<sup>7</sup>

3. HAC, FY 1986 EWDA, Part 4, pp. 427-29; HAC, FY 1985 EWDA, Part 4, p. 427.

4. HAC, FY 1987 EWDA, Part 4, p. 409.

5. HAC, FY 1983 EWDA, Part 4, p. 254.

6. HAC, FY 1984 EWDA, Part 4, p. 303.

7. HAC, FY 1985 EWDA, Part 4, p. 427.



---

## Savannah River Fuel and Target Fabrication Facilities

---

### Facilities<sup>a</sup>

Fuel fabrication and support activities are conducted in four 300 area facilities:

#### *Alloy Extrusion Plant (321-M)*

- Casting furnaces for preparation of HEU-aluminum billets
- Coextrusion of composite billets to form aluminum clad cores

#### *Uranium Metal Fabrication Plant (313-M)*

- Fabrication of aluminum-canned natural, depleted, and slightly enriched uranium metal target and fuel elements for SR reactors

#### *Target Extrusion Plant (320-M)*

- Extrusion of lithium-aluminum tubes for tritium production

#### *Metallurgical Laboratory (322-M)*

- Testing of materials fabricated in 300 area
- Examination of materials irradiated in SR reactors

#### *Fuel Production Facility (to be completed in 1988)*

- Conversion of enriched uranium to uranium oxide ( $U_3O_8$ )
- Production of  $U_3O_8$ -aluminum billets using powder metallurgy process for extrusion into driver fuel tubes, replacing processes for U-Al metal fuel.

---

<sup>a</sup> Duke and Benjamin, DPST-82-1654, p. 5-2.

## Savannah River Chemical Separations Facilities



Figure 71 F-Area SRP

**ADDRESS:** See Savannah River Plant

**LOCATION:** Fuel processing and other chemical separation facilities in 200 area at Savannah River Plant, occupying about 8 square kilometers near center of plant site

**MISSION:** Processing of irradiated SRP production reactor (1) driver fuel elements (in the 200-H area) for U-235 recovery; (2) natural or depleted uranium target elements (in the 200-F area) for plutonium recovery; and (3) enriched lithium target elements (in the 232, 234, and 238-H areas) for tritium recovery

**ESTABLISHMENT:** F-area and H-area chemical separation facilities became operational November 1954 and July 1955, respectively<sup>1</sup>

**FACILITIES:**

- 200-F Area Chemical Plant (including canyons)
- 200-H Area Chemical Plant (including canyons)

### Facilities (200-AREA OPERATIONS)<sup>2</sup>

Two large chemical plants (one in the 200-F area and one in the 200-H area) process reactor irradiated uranium. The F area plant recovers and separates Pu-239, Np-237, and U-238 from irradiated natural or depleted uranium targets. The H area plant recovers uranium isotopes, Np-237, and Pu-238 from irradiated enriched uranium fuel assemblies and converts the isotopes into a desired form for shipment.

<sup>1</sup> Environmental Radiation Surveillance Report, July 1962-June 1963, Georgia Department of Natural Resources, Environmental Protection Division, pp. 57-58.

<sup>2</sup> D.H. Stoddard and C.T. Randall, Safety Analysis—200 Area Savannah River Plant Separation Area Operations (DPSTSA-200-10, Savannah River Laboratory, August 1960), pp. III-2 - III-4.

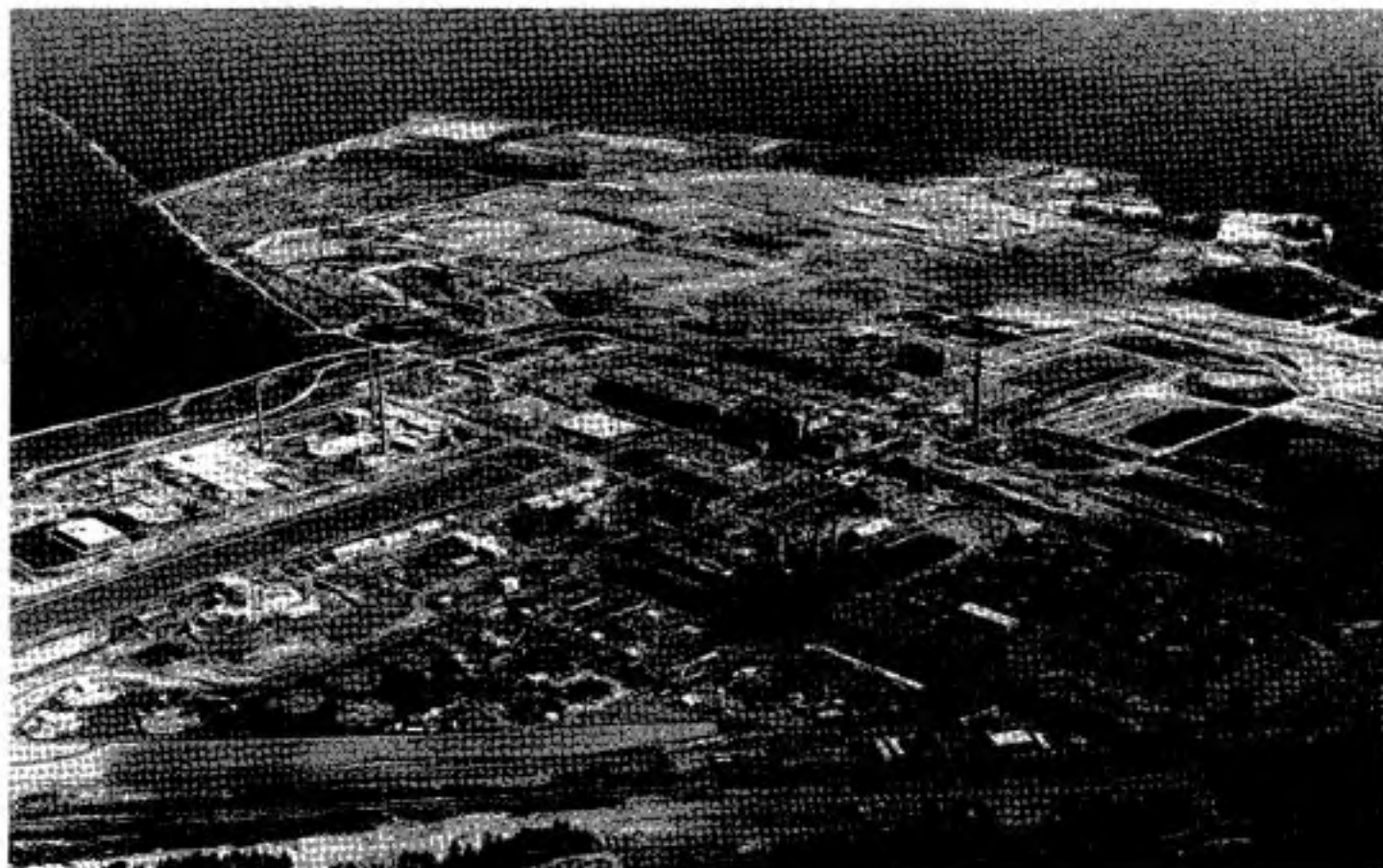

**Figure 72** H-Area SRP

Each chemical process facility, F and H plants, has two parallel "canyons" running south to north that constitute the process areas (see Figure 73): the heavily shielded hot canyon for processing high activity materials and the warm canyon for lower activity material. The canyons are 15 feet wide at the bottom and 30 feet wide at the top and are separated by four levels. The center section is largely a service and process auxiliary area and is also divided into four levels (see Figure 74).

The canyons contain equipment for the remote handling of radioactive materials. Significant pieces of process equipment rest on the floor.

After irradiation in the SR production reactors, spent fuel and targets are sent to the F and H area separation areas. There is an approximately six-month cooling period between fuel element discharge from reactor operations output and fuel reprocessing.

The relation between the various activities and processes is illustrated in the material flow diagram (Figure 75). The key operations involving the chemical separation areas facilities are summarized below.

*Chemical Separations Facilities: Building 221-F and H Canyon Operations:* Reactor irradiated materials are dissolved, then chemically treated to separate the various products. Major products and byproducts include isotopes of plutonium, uranium, and neptunium. High-level liquid wastes are evaporated and piped into storage tanks.

*Receiving Basin for Offsite Fuel (RBOF) Operations.* This operation includes the receiving and unloading of transport casks which contain reactor irradiated non-commercial fuel. These fuels are stored and in some instances are reloaded into casks for transport to the chemical separations facilities.

*Transportation.* Radioactive materials are transported between the facilities of the 200 Area.

*Burial Ground Facility, Building 643-G Operations.* Solid radioactive waste originating at the SRP site is stored at the burial ground (195 acres) in above- and below-ground locations. Disposal of solid radioactive waste at the burial ground began in early 1953.<sup>3</sup>

<sup>3</sup> Ibid.

## Savannah River Chemical Separations Facilities

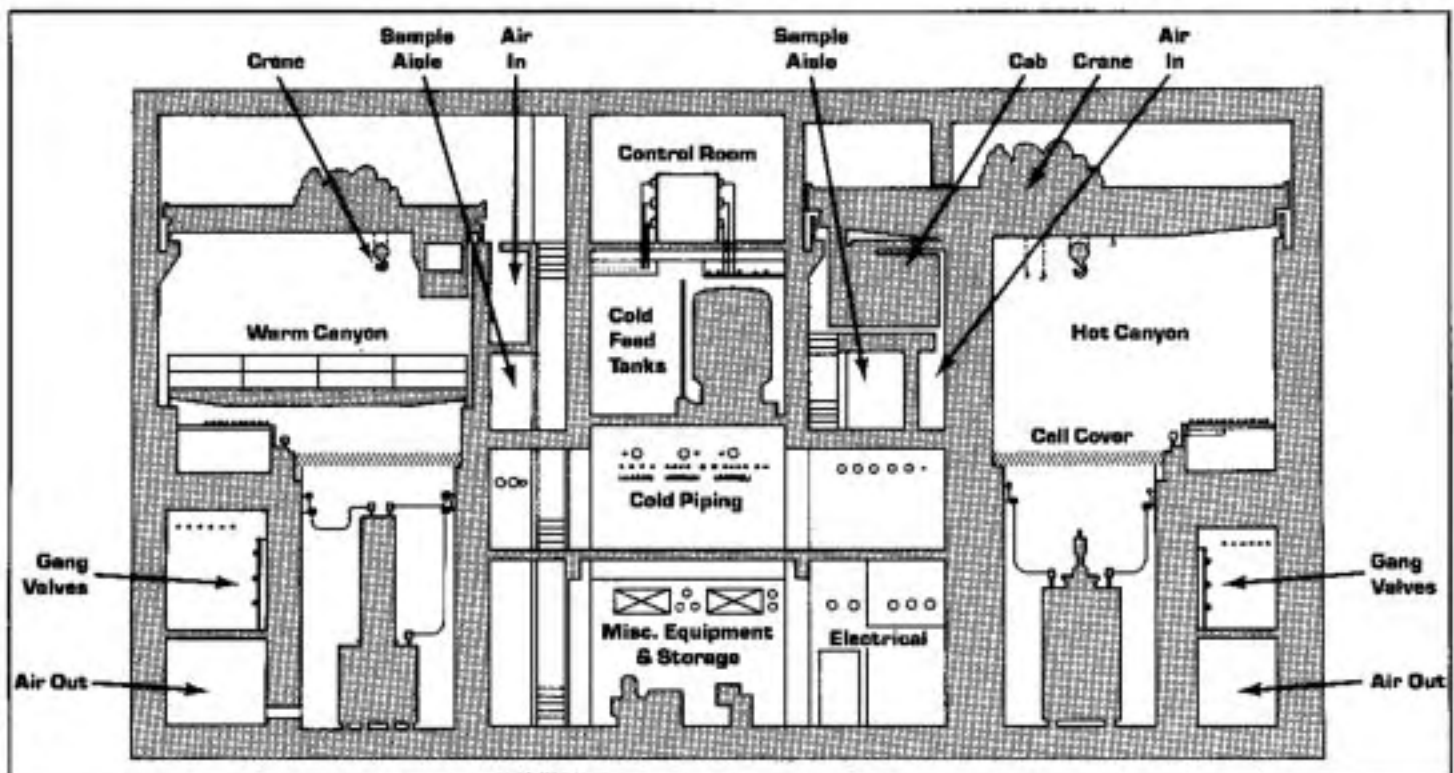

Figure 73 Separations Building Cross-Section

Source: D.H. Stoddard and C.T. Randol, Safety Analysis—200 Area Savannah River Plant Separation Area Operations (DPSTSA-200-10), Savannah River Laboratory, August 1980, p. III-21.

**A-Line Operations.** This F area facility converts recovered U-238 nitrate solutions into uranium trioxide powder. In H area, a uranium solution trailer-loading station is sometimes referred to as H area A-Line.

**Seepage and Retention Basins.** Liquid waste streams containing very low levels of radioactivity are disposed of through seepage basins where the liquid migrates through the soil, or evaporates. Process cooling water or storm drainage that may be contaminated are temporarily stored in retention basins until analyses can be obtained to determine disposition.

**JB-Line Operations.** This F area operation concentrates and purifies Pu-239 from the F area chemical separation facilities. Process operations include cation exchange, precipitation and filtering, drying and conversion, and reduction and finishing steps. Metal plutonium buttons are shipped from the facility. Recovery operations are also performed.

**HB-Line Operations.** Pu-238 and Np-237 from both chemical separations facilities are converted from liquids to powdered oxide form in this H area operation. Recovery operations are also performed. Both plutonium

and neptunium are shipped to other plant facilities, although the Pu-238 may also be shipped off-plant.

**Uranyl Nitrate to Oxide Conversion.** Currently HEU recovered in H Canyon is shipped as liquid uranyl nitrate to the Y-12 Plant at Oak Ridge for conversion to metal. DOE plans to build a conversion facility at SRP by late 1989 to replace the Y-12 facility, in use since 1959.<sup>4 5</sup>

### Process Descriptions

Casks containing material for processing are delivered by a plant-operated railroad to the hot canyon. In both the H and F chemical processing plants, the first step is to dissolve the fuel, a process that liberates volatile fission products and generates solutions with high concentrations of radioactivity. The initial separation yields solutions of plutonium, uranium, or neptunium product, and a high-activity liquid waste containing non-volatile fission products. After the fission products are removed sufficiently from the product solutions, further processing can be done in unshielded areas, where the products (e.g., plutonium and uranium) may be converted from solution form to solids.

4. HAC, FY 1986 RWD, Part 4, pp. 477-62.

5. ERDA, Savannah River Operations Office, "Integrated Radioactive Waste Management Plan, Savannah River Plant, Aiken, South Carolina," SRD-7WM-76-1, June 1976, pp. V-21 to V-28.





**Figure 74** Warm Canyon Interior One of the Chemical Separations Facilities at SRP prior to startup.

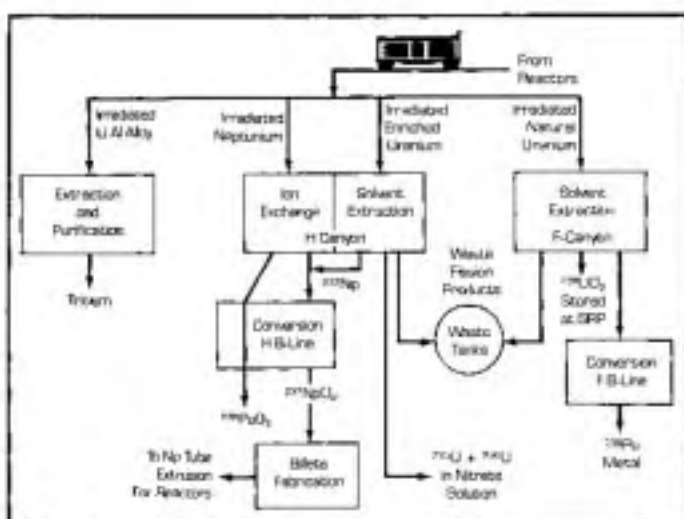

**Figure 75** Separations Processes in the 200 Area

Source: ERDA, "Visit by South Carolina and Georgia Environmental Groups, Savannah River Plant," Savannah River Operations Office, 24 March 1976

### Chemical Processing and Pu-239 Recovery in the F area

In the 221-F canyon building, the Purex solvent extraction process is used to recover Pu-239 from irradiated uranium. Special or subsidiary programs include processing of highly irradiated plutonium and recovery of neptunium. Neptunium oxide (NpO<sub>2</sub>) is used as a target material for Pu-238 production at SRP.

Fuel processing begins with dissolution of the fuel (see Figure 76). With the normal aluminum-clad, metallic uranium fuel, the aluminum cladding is dissolved in a sodium hydroxide-sodium nitrate solution, with evolution of ammonia and hydrogen. After the decladding solution with contained aluminum is removed, the declad fuel is dissolved in nitric acid.

In the first solvent extraction cycle, uranium and plutonium are extracted away from the remaining fission products with tributyl phosphate in a hydrocarbon diluent and then separated from each other. The low enriched uranium (LEU) and plutonium are further purified by separate second solvent extraction cycles. (For discussion of PUREX, see Volume II, Chapter Five.)

The final LEU product solution (uranyl nitrate) is concentrated and sent outside the canyon for conversion

## Savannah River Chemical Separations Facilities

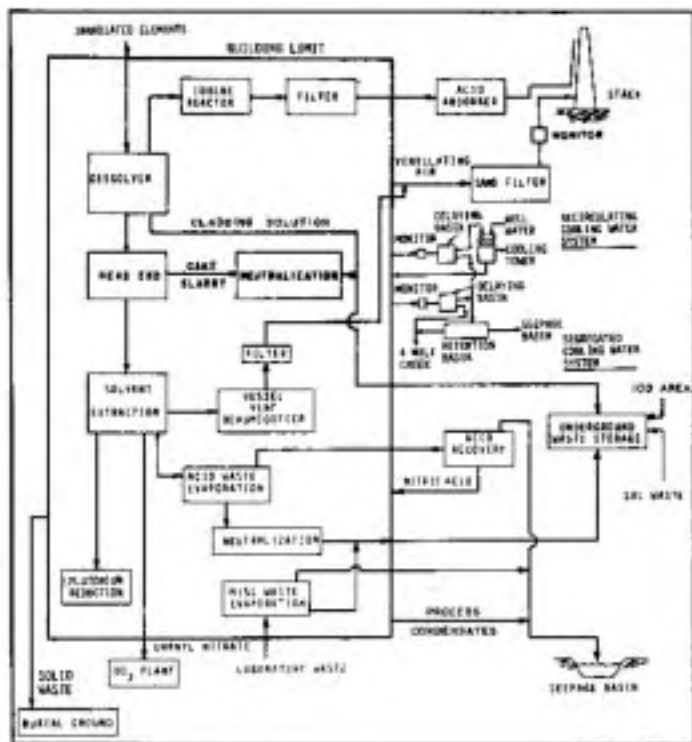

**Figure 76** F-Area Separations Diagram

Source: ERDA, Savannah River Operations Office, "Integrated Radioactive Waste Management Plan, Savannah River Plant, Aiken, South Carolina," SRD-TWM-76-1, June 1976, p. V-25.

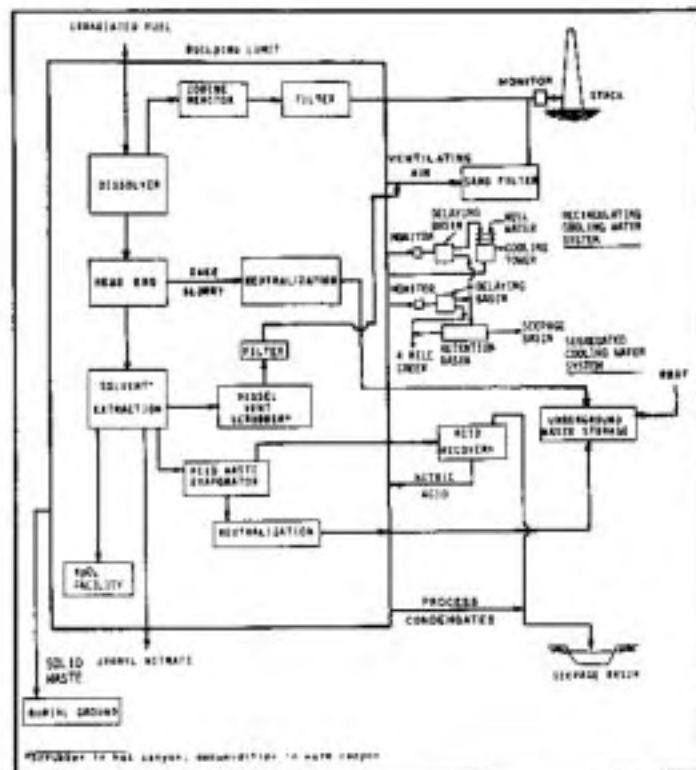

**Figure 77** H-Area Separations Diagram

Source: ERDA, Savannah River Operations Office, "Integrated Radioactive Waste Management Plan, Savannah River Plant, Aiken, South Carolina," SRD-TWM-76-1, June 1976, p. V-26.

to uranium trioxide in the A-Line of the 221-F building. The oxide powder  $U_3O_8$  is stored onsite. F area generates 2000 to 3000 drums of  $UO_2$  powder per year. Currently, there are also over 20,000 drums of depleted uranium oxide in long-term storage.<sup>6</sup>

In the warm canyon of the 221-F building, neptunium and residual plutonium are recovered by ion exchange from the fission product waste solution from solvent extraction. Neptunium is further purified by ion exchange, and the final product solution is sent to the H-area neptunium line, the HB-Line. (The HB-Line converts neptunium-237 and plutonium-238 from both chemical separations areas to powder.) The plutonium is sent to a separate operation, the JB-Line, atop the 221-F canyon building where the plutonium is concentrated by ion exchange, precipitated as fluoride, and, with some further treatments, reduced to metal buttons.<sup>7</sup> The metal buttons are shipped to Rocky Flats for manufacture into plutonium components of nuclear weapons.

An \$84 million Special Plutonium Recovery Facility for scrap recovery and blending operations is being constructed adjacent to the JB-Line atop the F separations building. It is scheduled for completion in FY 1987.

### U-235 Recovery in the H area

In the 221-H building the HM-process (or "H modified" PUREX process) is used to separate uranium, neptunium, and plutonium from irradiated fuels containing from 1.1 percent to 94 percent uranium-235. Before 1959 a PUREX process was used. Since then H area has been devoted primarily to recover enriched uranium from SRP fuel. Currently, this is mainly highly enriched uranium (HEU). Enriched uranium is also recovered from fuel of domestic research reactors and from foreign reactors fueled with material produced or enriched by the United States.

The H area facility dissolves fuels with a variety of claddings. Aluminum clad fuels are dissolved directly in nitric acid; zirconium or stainless steel cladding is first removed in an electrolytic dissolver (see Figure 77), with nitric acid electrolyte, and then the core material is dissolved chemically in nitric acid.

The solvent extraction operations are similar to those of the PUREX system (see PUREX, Volume II, Chapter Five). Some chemical processes are different because of differences in the fuels. Uranium and neptunium are extracted from the fission products and sepa-

<sup>6</sup> ISAC, FY 1985 EWRDA, Part 4, p. 445. Funding was requested in FY 1985 to construct a Uranium Oxide Repackaging Facility (221-1F) to repackage some 5000 drums that are rapidly deteriorating.

<sup>7</sup> Also, irradiated plutonium fuel and target assemblies may be processed in special programs in the main solvent extraction system and in the plutonium finishing system.

rated from each other in the first cycle; then each is further purified by two separate cycles of solvent extraction. The highly enriched uranium product (HEU) solution (uranyl nitrate) is not concentrated further but is transferred out of the building, loaded into tank trucks, and sent to the Y-12 Plant at Oak Ridge for conversion into metal to be recycled as driver fuel for the SRP production reactors. Low enriched uranium (2 to 3 percent U-235), from processing fuel in government owned test reactors, is recovered as uranyl nitrate and shipped to the Feed Material Production Center (Fernald Plant) for conversion into  $UF_6$  feed for the enrichment plants. The neptunium product solution is transferred to a separate area in the building for separate purification.

In a separate process system in the shielded H canyon, irradiated neptunium-237 targets are dissolved in nitric acid, and plutonium-238 and neptunium are separated from fission products and each other by a series of anion exchange resin columns. The product solutions of plutonium-238 and neptunium-237 are transferred to the finishing area, the HB-Line, where the two are concentrated, precipitated as oxalate, and calcined to oxides. The plutonium oxide is packaged for shipment offsite, and the neptunium oxide is sent to the metallurgical building (235-F) for refabrication into billets to be made into reactor target elements.

In addition to these main process efforts, various parts of the system have been used for special programs. Highly irradiated plutonium, for example, has been processed in both the solvent extraction and canyon anion exchange systems and finally discharged as oxide from the finishing area. A plutonium isotope mixture containing appreciable Pu-238 has been routinely recovered by solvent extraction from the fission product waste stream from enriched uranium processing. Irradiated thorium has been processed in the solvent extraction system to recover U-233 using the THOREX process.

#### Tritium Recovery

The Tritium Facility (buildings 232-H, 234-H, and 238-H) are a complex of buildings in which tritium is separated from irradiated lithium-aluminum targets, is further purified, and is packaged (see Figure 78). In the processing system, the lithium-aluminum targets are loaded into furnaces, and the gases are extracted under heat and vacuum. The furnace melts the aluminum housing and the matrix of the target to liberate the gaseous



Figure 78 Tritium Facility, SRP

tritium. The impure gas contains tritium, helium-4 (which has been formed along with tritium in neutron capture by lithium-6), helium-3 from tritium decay, and hydrogen (H-1) and deuterium (H-2) from the hydrated aluminum oxide surface of the targets. Thermal diffusion columns are used to purify the tritium.<sup>8</sup> The hydrogen isotopes are first separated from the helium isotopes, and then tritium is separated from ordinary hydrogen and deuterium.

Loaded tritium reservoirs are probably shipped directly to the Pantex Plant where weapon components are assembled into new nuclear weapons. Tritium decays radioactively, and the tritium reservoirs must be replaced periodically. Filled replacement reservoirs are shipped from SRP by air, truck, or other DOE approved transportation directly to Army Depots, Navy Installations, and Air Force Bases in 16-gallon metal drums.<sup>9</sup> Some 325 to 365 personnel (1980-83) are employed at the Tritium Facility.<sup>10</sup>

Tritium is currently recovered from weapons components at the Mound Facility. The gas, which is contaminated with helium-3, is then purified at Savannah River before reuse. Reclaiming components from the stockpile to reduce requirements for new production began at Savannah River in 1969.<sup>11</sup>

<sup>8</sup> DOE requested funds in FY 1986 to replace the thermal diffusion columns with a newly developed thermal absorption process. HASC, FY 1986 DOR, p. 277.

<sup>9</sup> AEC-DNA, "Transportation of Nuclear Weapons Material," Technical Manual, TP 43-51, 30 April 1973, p. 109.

<sup>10</sup> HASC, FY 1982 EWDIA, Part 7, p. 234; HASC, FY 1983 EWDIA, Part 6, p. 123.

<sup>11</sup> AEC, Report to Congress, January 1970, p. 72.



## Savannah River Heavy Water Plant

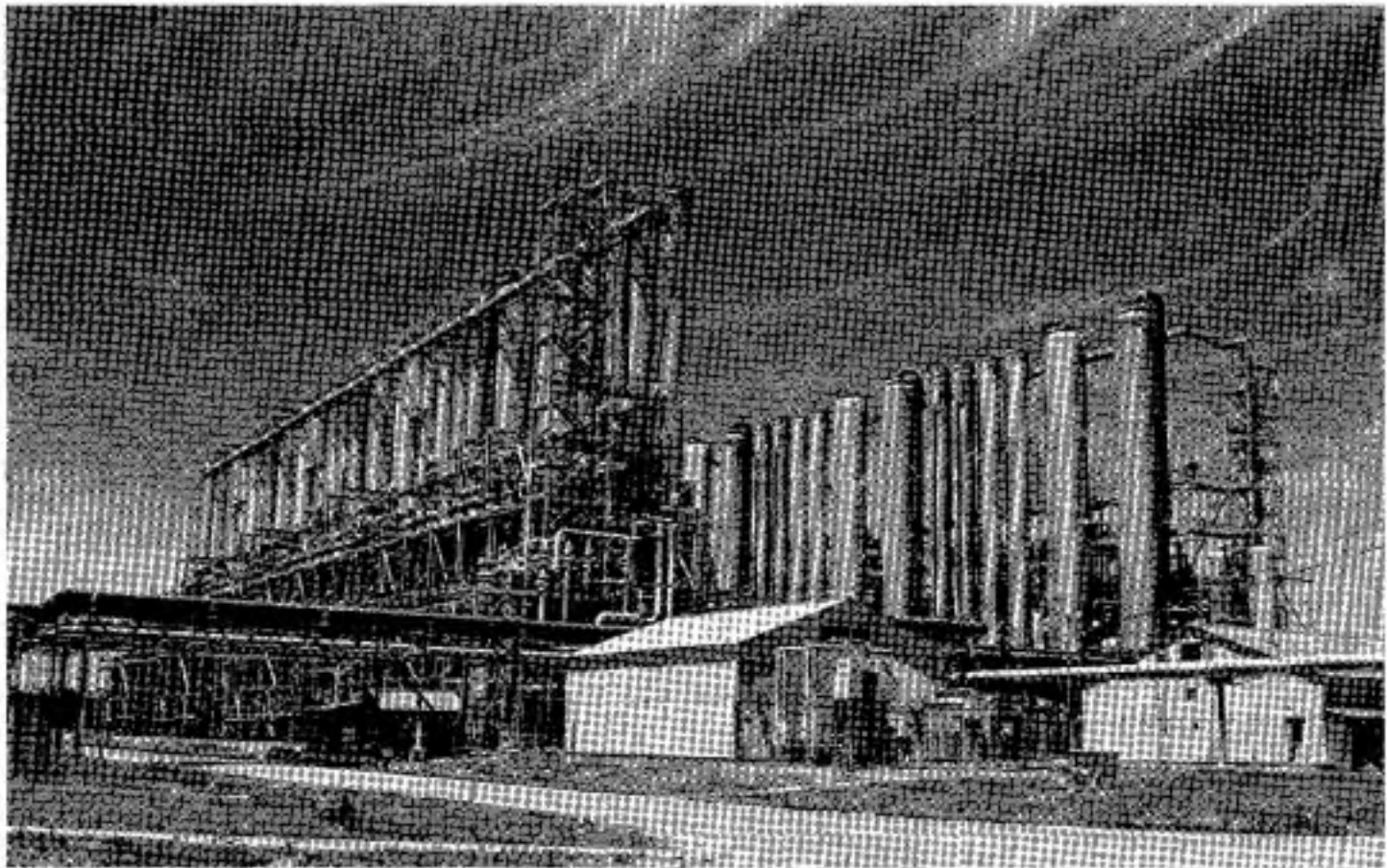

**Figure 79** Heavy Water Plant. The last of the three large heavy water separation units at SRP prior to shutdown.

<b>ADDRESS:</b>	See Savannah River Plant
<b>LOCATION:</b>	Heavy Water Plant and heavy water recovery facilities located in 400-D area at Savannah River Plant.
<b>MISSION:</b>	To provide a source of deuterium (D) for use in U.S. thermonuclear weapons (and the DOE fusion programs) and to provide heavy water (D <sub>2</sub> O) for use as the moderator in the production reactors at the Savannah River Plant (and other DOE research reactors); plant on standby since 1982.
<b>ESTABLISHMENT:</b>	Production operations started 1952

### History

The Heavy Water Plant began production operations in October 1952. After a staged shutdown, it was placed on standby in 1982 and "probably will never be restarted."<sup>1</sup> The plant had been essentially the only source of deuterium and heavy water in the United States.<sup>2</sup> It and a similar one at Dana, Indiana (operated 1952-1957) provided the original supply of moderator/coolant for the Savannah River reactors.

### Process Description

Heavy water (occurring naturally in a concentration of about 0.015 percent) was separated from raw Savannah River water by a combination of hydrogen sulfide-water chemical exchange and water distillation (and, at an earlier time, by electrolysis).

The hydrogen sulfide extraction process was used to increase the D<sub>2</sub>O concentration from its natural abundance (about 0.015 percent) to about 8 percent. The dis-

<sup>1</sup> Eukens and Benjamin, DPST-62-1864, p. 6-1.

<sup>2</sup> D.K. Johnson, SRP Process Description for L Reactor Restart, DPST-63-635, Savannah River Laboratory, 26 June 1983, p. 3.



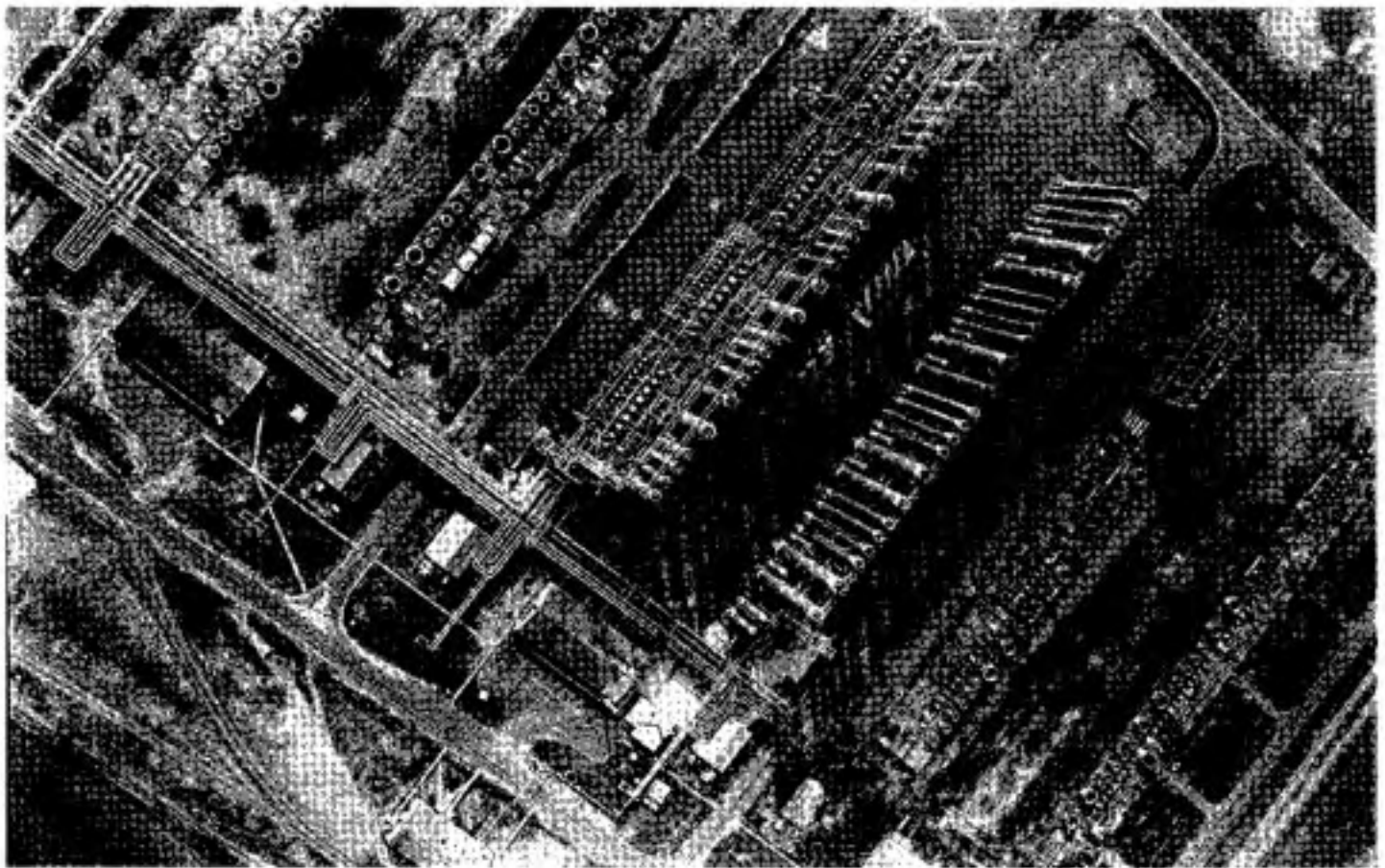

**Figure 80** Aerial View of Partially Dismantled Heavy Water Plant at SRP

tillation process was then used to reach reactor grade  $D_2O$  (greater than 99.75 percent) and to reconcentrate heavy water that had picked up light water during use.

Batch electrolysis was formerly used at the SRP heavy water plant to concentrate deuterium from 90 to 99.87 percent, but this final concentration step was not needed when the plant was operated at reduced capacity, as had been the case for the last several years before shutdown.<sup>3</sup> (For additional details, see Heavy Water Production, Volume II, Chapter Five.)

### Facilities

**Heavy Water Plant.** The Savannah River heavy water plant was constructed as three large units, each with eight separation units. Hydrogen sulfide gas was charged to the first unit in October 1952, and specification grade product (99.75 percent  $D_2O$ ) was produced in 1953.<sup>4</sup>

The plant was producing 450 MT/yr within five years after startup,<sup>5</sup> and an overall plant capacity of 480

MT/yr, or about 160 MT/yr for each of the larger units, was eventually achieved.

One of the larger units was shut down in January 1957, reducing the plant capacity by about one third. In January 1958 the capacity was reduced by yet another half by shutdown of a second large unit. These two large units were dismantled prior to 1979.<sup>6</sup> The one remaining large unit, with a capacity of about 177 MT, was operated at a reduced capacity of 65 to 69 MT/yr between 1977 and 1981. (see Figure 79)

In July 1980, to further reduce operating and maintenance expenses, DOE retired one half, or four, of the remaining separation units,<sup>7</sup> leaving a maximum capacity of about 90 metric tons annually. Retirement of these units terminate DOE's option of having a sprint capacity of 180 metric tons annually "should a defense need arise."<sup>8</sup>

In May 1982 DOE announced that it had terminated production of heavy water at Savannah River.<sup>9</sup> (see Figure 80)

<sup>3</sup> Benedict, et al., op. cit., p. 742.

<sup>4</sup> Donald W. Kubo, "D<sub>2</sub>O/H<sub>2</sub>O Separation," in *Reactor Handbook*, Vol. 1 Materials, edited by C.R. Tipton, Jr. (Interscience Publ., N.Y., 1960), p. 31.

<sup>5</sup> Letter from F.C. Gilbert, Acting Deputy Assistant Secretary for Nuclear Materials, DOE, to Thomas B. Cochran, 17 September 1961.

<sup>6</sup> HASC, FY 1980 DOR, p. 105.

<sup>7</sup> Letter from F.C. Gilbert, Acting Deputy Assistant Secretary for Nuclear Materials, DOE, to Thomas B. Cochran, 17 September 1981.

<sup>8</sup> HASC, FY 1982 DOR, p. 168.

<sup>9</sup> *NuclearWeek*, 3 June 1982.

---

## Savannah River Heavy Water Plant

---

Three-eighths capacity (65 MT/yr) was the minimum rate necessary to prevent corrosion and irreversible destruction of process equipment.<sup>10</sup> Damage due to corrosive action was minimal for shutdown periods up to six weeks; once the plant was shut down for a six-month period, it could not be restarted due to self-destruction through corrosive action.<sup>11</sup>

<b>CHRONOLOGY:</b>	<b>Heavy Water Plant</b>
1952	Startup of first unit
1953	First production of 99.75 percent D <sub>2</sub> O
1953-56	Production increased to 450 MT/yr
Jan 1957	One unit shut down; capacity reduced to 320 MT/yr
Jan 1958	Second unit shut down; capacity reduced to 177 MT/yr
1958-76	Operation of one unit at capacity of 177 MT/yr
1977-early 1982	Operation at 65 to 69 MT/yr (three-eighths capacity)
1982	Operations terminated

*Moderator Rework Unit*<sup>12</sup> The Rework Unit, which remains in operation, consists of four distillation towers and associated equipment for removing ordinary water (H<sub>2</sub>O) that has accumulated in the D<sub>2</sub>O reactor coolant during reactor operation. The unit operates both a waste campaign and a product campaign. Feed for the waste campaign is highly degraded coolant containing 1.25 to 40 percent D<sub>2</sub>O, and the product (which is stored as feed for the product campaign) contains about 50 percent D<sub>2</sub>O. Feedstock for the product campaign is degraded coolant with a concentration of 40 to 90 percent D<sub>2</sub>O. Production is withdrawn at a concentration above 99 percent for shipment to the reactors.

*Driver Cleaning Facility (421-D)*<sup>13</sup> Fifty-gallon drums used for heavy water storage and transport are cleaned with either acid or alkaline phosphate solutions before reuse.

*Analytical Laboratory (772-D)*<sup>14</sup> The quality control laboratory in the 400 area is a support facility serving both the heavy water area and the reactor areas.

For inventory, stockpile, and sales figures see Volume II, Tables 3.25 and 3.26.

---

10 HASC, FY 1980 DOE, pp. 285-86.

11 *Ibid.*, also at p. 71.

12 Duke and Benjamin, DPST-62-1054, p. 6-1.

13 *Ibid.*

14 *Ibid.*

## Tonopah Test Range (TTR)<sup>1</sup>

<b>ADDRESS:</b>	Sandia National Laboratories P.O. Box 871 Tonopah, NV 89049 702/295-8234
<b>LOCATION:</b>	Nye County, Nevada, 32 miles southeast of Tonopah, Nevada, and 140 miles northwest of Las Vegas; approximately 369,230 acres (577 square miles; bordered on three sides by Nellis Air Force Base Bombing and Gunnery Range (see Figure 30)
<b>MISSION:</b>	A test site of the Sandia National Laboratories for the ballistics of nuclear weapons, parachutes, and other non-nuclear functions and parameters associated with nuclear weapons
<b>MANAGEMENT:</b>	Operated for DOE by Sandia National Laboratories (SNL) under management of Albuquerque Operations Office (Sandia Laboratories operated by Sandia Corporation, subsidiary of Western Electric Company, which is subsidiary of AT&T); land is owned by Air Force
<b>ESTABLISHMENT:</b>	1957
<b>BUDGET:</b>	(See Sandia National Laboratories)
<b>PERSONNEL:</b>	(See Sandia National Laboratories)
<b>FACILITIES:</b>	<ul style="list-style-type: none"> <li>• Rocket launchers</li> <li>• Mounts for gun barrels</li> <li>• Static rocket test pad</li> <li>• Drop targets</li> <li>• Towers to support cameras and telemetry decoding and coding</li> <li>• Stations for telescopes and radars</li> <li>• Explosive storage facilities</li> </ul>

### History

The Tonopah Test Range was established in 1957. At that time it came into limited use after similar facilities at Salton Sea Test Base, California, and at Yucca Flat on the Nevada Test Site became inadequate. The TTR site was a bombing range during World War II.

### Nuclear Weapons Activities

Testing activities at TTR have included air drops of simulated bombs, gun firings of artillery shells, ground launched rockets (for ballistics or materials properties measurements), rocket launches from aircraft, static rocket tests (e.g., for the TRIDENT I), use of the range as an impact area for cruise missiles launched from ships and submarines at sea, and explosive tests on shipping and storage containers for nuclear weapons. Some of the latter tests have involved plutonium and kilogram quantities of depleted uranium and beryllium.

### Non-nuclear Weapon Activities

TTR is used for measurements of weapons ballistics, rocket and gun firings, and various tests with conventional chemical explosives.

In 1963 a series called the Roller Coaster tests were carried out to study the spread of plutonium from the nonnuclear detonation of nuclear weapons, contaminating the area.

### Assets

(See Sandia National Laboratories)

<sup>1</sup> ERDA, Environmental Assessment, Tonopah Test Range, 2nd printing, September 1977; Tonopah Test Range, Sandia Technology, October 1983.

## Uranium Enrichment Enterprise



**Figure 81** Aerial View of Oak Ridge Gaseous Diffusion Plant

**ADDRESS:** Oak Ridge Operations Office  
P.O. Box E  
Oak Ridge, TN 37830  
502/444-6301 (Paducah)  
614/289-2533 (Portsmouth)  
615/574-9200 (Oak Ridge)

**LOCATION:** Facilities of Enrichment Enterprise at following locations:

- Paducah Gaseous Diffusion Plant (GDP): Paducah, Kentucky
- Portsmouth GDP: Piketon, Ohio
- Oak Ridge GDP: Oak Ridge, Tennessee (on standby since end FY 1985)
- Centrifuge Plant Demonstration Facility (CPDF) (R&D Pilot Plant): Oak Ridge, Tennessee (shut down end of FY 1984)
- Gas Centrifuge Enrichment Plant (GCEP): Portsmouth GDP at Piketon, Ohio (cancelled while under construction in FY 1985)

**MISSION:** The DOE uranium enrichment complex was constructed originally to produce highly enriched uranium for nuclear weapons. It is now used primarily to provide low enriched uranium (up to 5 percent U-235) for domestic and foreign nuclear power reactors and, to a lesser degree, to provide the highly enriched uranium used in nuclear propulsion (naval) reactors and some research and test reactors.

**MANAGEMENT:** Oak Ridge, Paducah, and Portsmouth are GOCO facilities administered through Oak Ridge Operations Office; Oak Ridge and Paducah managed for DOE by Martin Marietta Energy Systems, Ins.; Portsmouth GDP by Good-year Atomic Corporation; Ports-





Figure 82 Aerial View Paducah Gaseous Diffusion Plant



Figure 83 Aerial View Portsmouth Gaseous Diffusion Plant

mouth GCEP was to be managed by Goodyear Atomic.

**BUDGET:** \$1388.5 million, total Oak Ridge, Paducah, Portsmouth GDP (1986)

**PERSONNEL:** 8267 total Oak Ridge, Paducah, Portsmouth GDP (March 1985)

**Gaseous Diffusion Plants (GDPs)**

The enrichment complex consists of three gaseous diffusion plants: Paducah, Portsmouth, and Oak Ridge. Oak Ridge was placed on standby at the end of FY 1985.

The gaseous diffusion plants operate as an integrated complex in order to provide the best use of these facilities. The Paducah plant serves as the bottom stage for the Portsmouth plant (and previously the Oak Ridge Plant), with most of the enriched product from Paducah shipped to Portsmouth for further enrichment. Portsmouth is the only plant capable of producing intermediate and high assay (i.e., high percentage of U-235) uranium. Oak Ridge is restricted to a maximum enrichment of about 4 percent and Paducah to a maximum of about 2 percent.<sup>1</sup>

**GDP Separative Work Capacity**

The capacities of the three gaseous diffusion plants, with the recent Cascade Upgrading and Cascade Improvement Programs (CUP/CIP), are:<sup>2</sup>

Oak Ridge: 7.7 million SWU/year  
 Paducah: 11.3 million SWU/year  
 Portsmouth: 8.3 million SWU/year  
 TOTAL: 27.3 million SWU/year.

At design conditions of the Cascade Upgrade Program (CUP), the plants have the following stream assays:

**Paducah**

Option	% U-235 Feed	% U-235 Product	% U-235 Tails
1.	0.711	1.0*	0.20

**Portsmouth**

Option	% U-235 Feed	% U-235 Product	% U-235 Tails
1.	0.711	1.7	0.20
2.	1.0*	2.6	0.20
3.	various high assay feeds	3.2	0.20
4.	various high assay feeds	various high assay products	0.20
5.	various high assay feeds	97.30 maximum	0.20

\* Paducah product is shipped to the Portsmouth plant for further enrichment.

These assays represent the design conditions. Under actual operating conditions the feed and product assays would vary according to the assay of the material delivered to the plants and the actual product assay requirements of customers.

1. Wm. R. Voigt, Jr., Acting Deputy Assistant Secretary, Uranium Enrichment and Assessment, DOE Office of Nuclear Energy, letter to Thomas B. Cochran, 11 August 82.  
 2. A separative work unit (SWU) is a measure of work done in isotope enrichment (see Volume II, Chapter Five). The CIP program was initiated in 1971 to increase the combined plant capacity by 5.5 million SWU/yr at no increase in plant power. The CUP program was

initiated in 1974 to increase plant capacity by approximately 4.0 million SWU/yr. at a plant power increase of approximately 1300 Mw. Prior to CUP/CIP the capacities were Oak Ridge: 4.73 million SWU per year, Paducah: 7.31 million SWU per year, and Portsmouth: 5.19 million SWU per year.



**Figure 86** Paducah Gaseous Diffusion Plant

Source: PNL-4621 Draft, Pacific Northwest Laboratory, March 1983, pp. 16.2, 16.3.

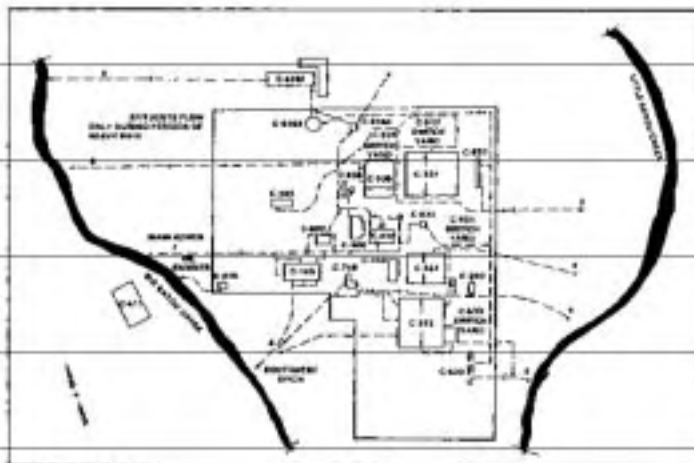
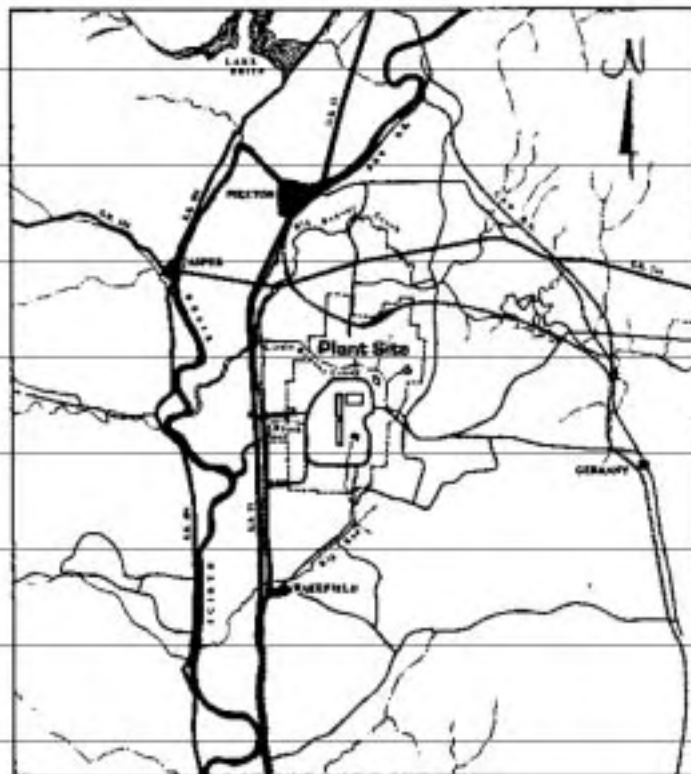

**Figure 87** Paducah Gaseous Diffusion Plant. Site Plan

Source: PNL-4621 Draft, Pacific Northwest Laboratory, March 1983, pp. 18.2, 18.3.

### Advanced Isotope Separation

The DOE Advanced Isotope Separation (AIS) Program focused on three processes for enriching uranium in U-235: atomic vapor laser isotope separation (AVLIS), molecular vapor laser isotope separation (MLIS), and the plasma separation process (PSP). At the end of April 1982 AVLIS was selected over the other processes for further engineering development and demonstration at the LLNL.<sup>8</sup> In June 1985 DOE chose AVLIS over the gas centrifuge as the process that would be developed to eventually augment or replace the gaseous diffusion plants. At the time of the decision only about five kg of uranium had been enriched to 3.2 percent in the AVLIS project.<sup>9</sup>

The next stage in the AVLIS uranium enrichment program is demonstration at the LLNL Special Isotope

**Figure 88** Map of the Portsmouth Gaseous Diffusion Plant

Source: PNL-4621 Draft, Pacific Northwest Laboratory, March 1983, pp. 17.2, 17.3.

Separation Laboratory (SISL) in 1988 in a 1 million SWU per year capacity module. This would be followed by construction of a full-scale 10 million SWU per year commercial facility, with startup in the mid-1990s at a project cost of \$1.2 to \$1.6 billion (FY 1985).<sup>10</sup>

### Gas Centrifuge

Gas centrifuge technology R&D and testing was conducted by DOE at the K-25 site on the Oak Ridge Reservation, also the site of the Oak Ridge GDP. One hundred and twenty Set III gas centrifuges were installed and tested in the Centrifuge Plant Demonstration Facility (CPDF) in Oak Ridge. CPDF completed its mission and was shut-down.

The gas centrifuge enrichment plant (GCEP) at Portsmouth was originally scheduled for completion by 1994, with construction of eight process buildings at an estimated cost of \$9 billion.<sup>11</sup> When the plant was cancelled in June 1985 \$2.6 billion had already been spent.

The first increment of GCEP, with 2.2 million SWU capacity in two process buildings (each 1.1 million SWU), was planned for 1989. A portion of the first building, the first train of Set III machines (each building is divided into eight trains of 720 centrifuges each), went

<sup>8</sup> The developers of the other candidate technologies are: MLIS—Los Alamos National Laboratory with support from Oak Ridge GDP; PSP—TRW, Los Angeles. All three technologies are still under development for isotope enrichment (see Volume II, Chapter Three).

<sup>9</sup> Nuclear Fuel, 29 July 1985, p. 4.

<sup>10</sup> Nuclear Fuel, 29 July 1985, p. 2.

<sup>11</sup> Science, 19 August 1983, p. 730.

## Uranium Enrichment Enterprise

on-line to enrich uranium in 1985. Four trains of Set III machines were procured before termination. Each building was to house 5760 centrifuges.<sup>12</sup> When completed, the plant was to have an annual capacity that reflected the state of centrifuge development in the late 1980s, and the capacity was to be several times the 8.8 million SWU originally anticipated as the baseline Set II machines alone.<sup>13</sup> Using Set IV machines developed at Oak Ridge would have raised the capacity to the 13.2 million SWU capacity level (1.65 million SWU per building). Eventually, use of advanced gas centrifuge (AGC) machines would have increased GCEP capacity to 26.4 million SWU after 1994 (3.3 million SWU per building).

Set III machines had a verified annual capacity of 200 SWU per machine, as demonstrated in the Centrifuge Plant Demonstration Facility (CPDF). Set IV machines were designed to produce about 300 SWU per year (1.5 times Set III) and, as of mid-1983, had been demonstrated at about 280 SWU. Set V machines were being designed to produce 400 to 600 SWU per year (up to 3 times Set III) and were to be ready for demonstration by early 1987.<sup>14</sup>

### Comparative Costs

Comparative power requirements and SWU costs for the various enrichment technologies are as follows:<sup>15</sup>

Enrichment Technology	Power Requirement kwh/SWU	Power Cost \$/SW
GD	2210	90-120
GC Baseline	110	90
GC AGC	110	40-60
AVLIS	110	25-50

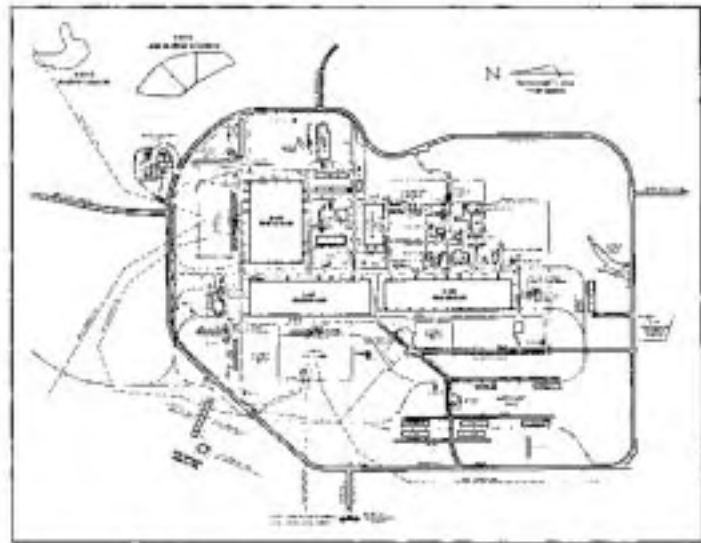

Figure 89 Portsmouth Gaseous Diffusion Plant Site Plan

Source: PNL-4821 Draft, Pacific Northwest Laboratory, March 1983, pp. 17.2, 17.3

### Management

The Paducah, Portsmouth, and Oak Ridge plants are GOCO operations administered through the Oak Ridge Operations Office. Paducah and Oak Ridge GDPs are managed for DOE by Martin Marietta Energy Systems, Inc. under a contract that became effective 1 April 1984.<sup>16</sup> Prior to that the DOE contractor was Union Carbide, Nuclear Division (UCCND) under a contract that expired 30 September 1983. The Portsmouth GDP is managed for DOE by the Goodyear Atomic Corporation under a contract that expires in 1988. The Portsmouth GCEP was to have been operated for DOE by Goodyear Atomic. UCCND was the key contractor in the Gas Centrifuge Program.

12. Nuclear Fuel, 17 February 1984, p. 2.

13. Nuclear Fuel, 17 January 1983, p. 14.

14. The major centrifuge manufacturers were Boeing Engineering and Construction Company, Oak Ridge, Tennessee; Garrett Corporation, Sandusky, Ohio; and Goodyear Aerospace Corporation, Akron, Ohio. Advanced Gas Centrifuge and R&D and manufacture were also conducted by AdResearch Corporation (division of Garrett Corporation, Torrance, California), and Seal Beach Naval Weapons Station, California; the University of Virginia, LLNL, and LANL; Hearings of the House Science and Technology Subcommittee on Energy Research and Production, Vol. VI, March 1982, p. 109.

15. DOE, Uranium Enrichment, 1982 Annual Report, ORO-8229.

16. See Oak Ridge Reservation.



Uranium Enrichment Enterprise

Enrichment Production, Sales, and Inventory<sup>17</sup>  
(million SWU)

BUDGET:  
(\$ million)

Oak Ridge Gaseous Diffusion Plant

End FY	Production	Sales	Inventory		FY	PowerCost <sup>25</sup>	Total Oak Ridge GDP
			In-Process	Finished			
1971	6.640	8.836		13.232	1971	21.3	55.0
1972	8.353	5.419		17.702	1972	23.3	63.4
1973	10.355	8.178		17.379	1973	44.9	100.3
1974	10.415	12.441		15.251	1974	55.2	135.8
1975	11.627	6.980		19.471	1975	85.6	183.3
1976	18.014	10.149		25.675	1976*	189.6	319.3
1977	15.090	10.521	2.292	29.459	1977	151.8	370.5
1978	12.550	12.408	1.820	30.029	1978	138.2	334.8
1979	13.870	14.793	0.356	32.325	1979	159.9	357.3
1980	10.817	10.815	0.274	32.409	1980	181.5	420.4
1981	9.620	11.840	0.823	29.840	1981	196.9	456.6
1982	9.777	15.236	0.460	24.544	1982	279.2	541.0
1983	10.177	15.076	0.151	19.964	1983	280.7	
1984	11.348	12.338	1.043	18.082	1984 <sup>26</sup>	320.4	725.2
1985 <sup>18</sup>	10.4	11.2	1.3	17.0	1985		629.9
					1986		673.3

For Defense Activities

Price to Government  
Agencies  
(\$/SWU)

\* 1976 was a 15-month fiscal year.

End FY	For Defense Activities		Price to Government Agencies (\$/SWU)
	Naval Reactors	Production Reactors	
1971			
1972			
1973			
1974			
1975			
1976			
1977			
1978			
1979			
1980	0.8 <sup>19</sup>	-	
1981	1.4 <sup>19</sup>	-	
1982	1.2 <sup>19</sup>	-	
1983	1.21 <sup>20</sup>	-	90
1984	1.29 <sup>20</sup>	0.22 <sup>21</sup>	93
1985 <sup>14</sup>	1.26 <sup>21</sup>	0.23 <sup>21</sup>	98.06
1986	2.47 <sup>22</sup>	0.12 <sup>22</sup>	82.12-100.80 <sup>24</sup>

Paducah Gaseous Diffusion Plant

FY	PowerCost <sup>25</sup>	Total Paducah GDP
1972	65.4	92.6
1973	77.0	107.9
1974	88.6	130.6
1975	140.1	197.6
1976*	280.2	410.1
1977	235.6	405.1
1978	224.1	373.7
1979	254.0	388.1
1980	260.2	373.3
1981	272.2	359.5
1982	350.4	437.0
1983	354.1	
1984 <sup>20</sup>	379.9	446.7
1985		468.6
1986		464.5

\* 1976 was a 15-month Fiscal Year.

17 DOE, Uranium Enrichment, Annual Reports.  
 18 Private communication, Oak Ridge Operations Office.  
 19 HAC, FY 1982 EWDA, Part 5, p. 1110.  
 20 HAC, FY 1984 EWDA, Part 4, p. 499.  
 21 HAC, FY 1985 EWDA, Part 4, p. 421; FY 1986, p. 376.  
 22 HAC, FY 1986 EWDA, Part 4, pp. 376, 378, 381, 1044.  
 23 HAC, FY 1984 EWDA, Part 4, pp. 280, 310, 490; HAC, FY 1986 EWDA, Part 4, p. 376.  
 24 Dual price: \$100.80 per SWU for enrichment greater than 5 percent and \$82.12 per SWU for enrichment less than 5 percent.

25 Cost of power supplied to the Cascade.

26 DOE, Uranium Enrichment, 1984 Annual Report, DOE/OE-956.

## Uranium Enrichment Enterprise

Portsmouth GDP		
FY	PowerCost <sup>25</sup>	Total Portsmouth GDP
1971	19.5	39.3
1972	40.2	64.2
1973	46.2	75.9
1974	54.8	93.2
1975	91.0	155.9
1976	162.1	292.6
1977	177.6	293.6
1978	192.3	323.1
1979	251.1	374.2
1980	125.4	247.6
1981	147.2	293.4
1982	136.8	451.5
1983	131.9	
1984	173.4	337.7
1985		423.5
1986		250.7

PERSONNEL: <sup>26</sup>				
FY	Oak Ridge GDP	Paducah GDP	Portsmouth GDP	Total
1971	2750	1177	1371	5298
1972	2783	1226	1374	5383
1973	3077	1293	1464	5834
1974	3490	1477	1633	6600
1975 (Sep)	4849	1860	2408	9117
1976	5872	2289	2793	10954
1977	6333	2464	2961	11758
1978	6275	2404	3006	11685
1979	6177	2291	3078	11546
1980	6031	1938	3144	11113
1981	5236	1621	3286	10143
1982	4527	1411	3224	9162
1983	4313	1353	3016	8682
1984	3963	1314	3125	8402
1985 (Mar)	3869	1289	3109	8267

### ASSETS

The enrichment facilities of the gaseous diffusion plants cover a ground area of 271.1 acres: 97.7 acres at Portsmouth, 73.7 acres at Paducah, and 104.7 acres at Oak Ridge (including 56.1 acres by the K-25 and K-27 buildings). The total investment in plant and capital equipment at the three gaseous diffusion plant sites at the end of FY 1984 was \$3.86 billion: \$1.30 billion at Portsmouth, \$1.39 billion at Paducah, and \$1.16 billion at Portsmouth. The investment in the cancelled GCEP was about \$2.6 billion.<sup>27</sup>

<sup>27</sup> DOE, Uranium Enrichment, 1984 Annual Report, DOE/OR-656.

<sup>28</sup> DOE, GOCO Employment, Computer printout for Office of Industrial Relations, R-5575309-012, 29 August 1985.









